

Picoprobe®

BY GGB INDUSTRIES INC.

Model 67A

High Performance Microwave Probes

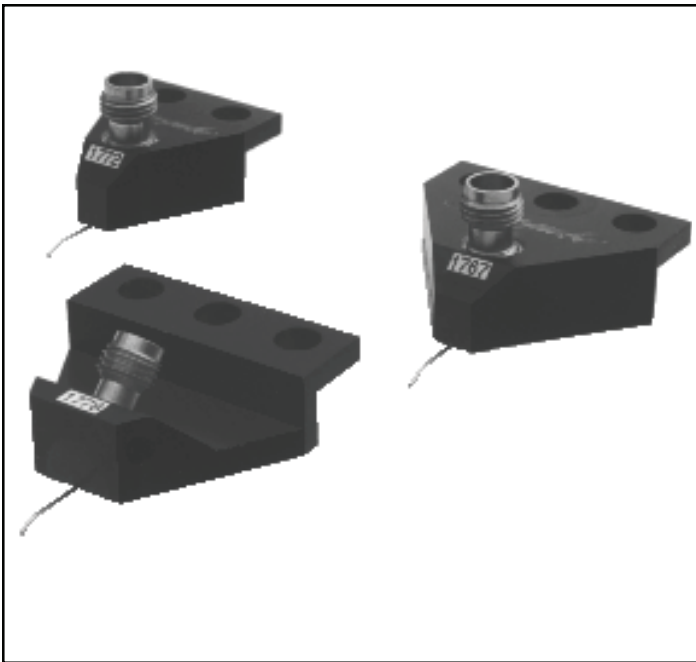

Model 67A probes mounted in three different adaptor styles

The GGB Industries Model 67A probe sets new standards in microwave probing performance. Using low loss coaxial techniques, the Model 67A achieves an insertion loss of less than 1.1 db and a return loss of greater than 14 db through 67 GHz

With its individually spring loaded, Beryllium-Copper tips, the Model 67A provides reliable contacts, even when probing

non-planar structures. This reliable low resistance contact is one of the keys to providing highly repeatable measurements. The Model 67A also provides direct viewing of the probe tips for accurate positioning.

The Model 67A can be mounted in various adaptors for use with standard microwave probe stations. Custom mounts are available.

Features

- **Durable**
- **DC to 67 GHz**
- **Insertion loss less than 1.1 db**
- **Return loss greater than 14 db**
- **Measurement repeatability -50 db**
- **Individually spring loaded contacts**
- **BeCu or Tungsten tips available**
- **Any pitch from 50 to 1250 microns**
- **Variety of Footprints**
- **Patented coaxial design**

Any pitch (tip spacing) from 50 to 1250 microns may be specified. The probe can be configured with Ground-Signal-Ground (G,S,G), Ground-Signal (G,S), or Signal-Ground (S,G) tip footprints. We recommend smaller pitches with a G,S,G footprint for best performance.

Connection to the Model 67A is through a female 1.85 mm V connector. (2.4 mm compatible)

Flexible Tips for Flexible Probing

Each Model 67A has patented, independently spring loaded tips which make contact to the probing surface. Because the tips are flexible they minimize circuit damage, increase probe life, and most importantly, provide a reliable individually spring loaded contact for each point. With a small amount of overdrive, the point scrubs the surface to make a reliable contact free of dust, dirt, and oxide contamination. The ability to view the exact contact area eases probe positioning and allows for the precise positioning necessary for good LRM calibrations. The flexible tips even allow probing of non-planar surfaces such as ceramic substrates and laser diode structures.

Coaxial Transmission Improves Performance

The Model 67A uses a precision miniature 50 ohm coaxial cable from the probe tips to the connector interface. The coaxial design provides lower loss and less radiation than coplanar designs. The miniature coaxial cable is fabricated from flexible Beryllium-Copper which greatly improves the probe's durability.

Probe Cards

Model 40A probes can be mounted on standard 4.5 inch probe cards to provide a convenient method for testing wafers at high frequencies using standard automatic or manual probe stations. Picoprobe Cards combine our Model 40A probes for RF connections with DC needles for power and low frequency signals.

Line of Microwave Probes

Other models of Microwave probes are available with standard tip spacings of up to 1250 microns. Larger spacings are possible. For special applications, the Model 67A can be mounted in custom adaptors, the coaxial line can be bent to fit tight spaces, and the tips can be configured to match extremely non-planar surfaces or non-symmetrically placed grounds.

Three models are available with wave guide inputs. WR-22 for 33 to 50 GHz, WR-15 for 50 to 75 GHz, and WR-10 for 75 to 110 GHz. The wave guide probes have an integral bias T for active device measurements.

For applications below 40 GHz, GGB Industries offers the Model 40A Picoprobe which uses the 2.95mm K connector. The Model 40A performs up to 40 GHz with less than 1.0 db (0.7 db typical) insertion loss and return loss of greater than 18 db.

Many other types are available, please call.

Probing Expertise

GGB Industries is the leading supplier of high impedance active probes offering models with input capacitances of as low as .02 pF and frequency responses of up to 3.0 GHz. With 22 years of probing experience, GGB Industries has broad capabilities in custom probe engineering.

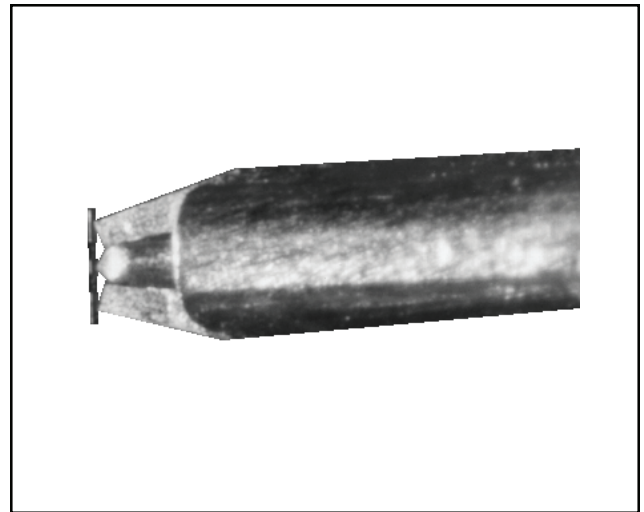

Closeup of Model 67A Tips with 150 Micron Pitch almost touching a 50 Ω calibration load.

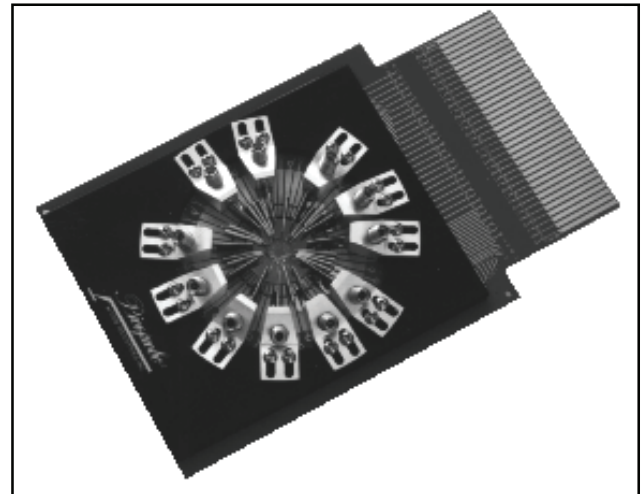

Typical Probe Card with Model 40A Probes

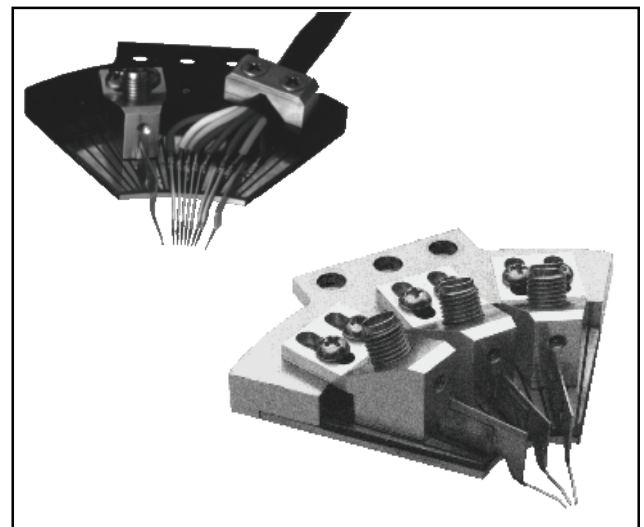

Examples of the Multi-Contact Wedge which combine Multiple RF and DC contacts .

Model 67A Performance Data¹ G,S,G Configuration

Frequency Range:	DC to 67 GHz
Insertion Loss:	Less than 1.1 db to 67 GHz (.95 db typical)
Return Loss:	Less than 35 db to 4 GHz (35 db typical) Less than 20 db to 26 GHz (23 db typical) Less than 18 db to 40 GHz (20 db typical) Less than 14 db to 67 GHz (16 db typical)
Crosstalk²:	Less than 35 db to 67 GHz

¹ Specifications are for the P-style Model 67A Picoprobes with G,S,G configurations and pitches of between 50 and 250 microns. The C and T style Model 67A Picoprobes (see following page for mounting styles) have the same specifications except for insertion loss, which is less than 1.3 db (1.2 db typical).

² Crosstalk is measured using two probes contacting a bare sapphire substrate 100 microns apart.

Model 67A Performance Data³ G,S and S,G Configuration

Frequency Range:	DC to 67 GHz
Insertion Loss:	Less than 1.0 db to 40 GHz (0.9 db typical)
Return Loss:	Less than 30 db to 4 GHz Less than 15 db to 26 GHz Less than 12 db to 40 GHz

³ Specifications are for the P-style Model 67A Picoprobes

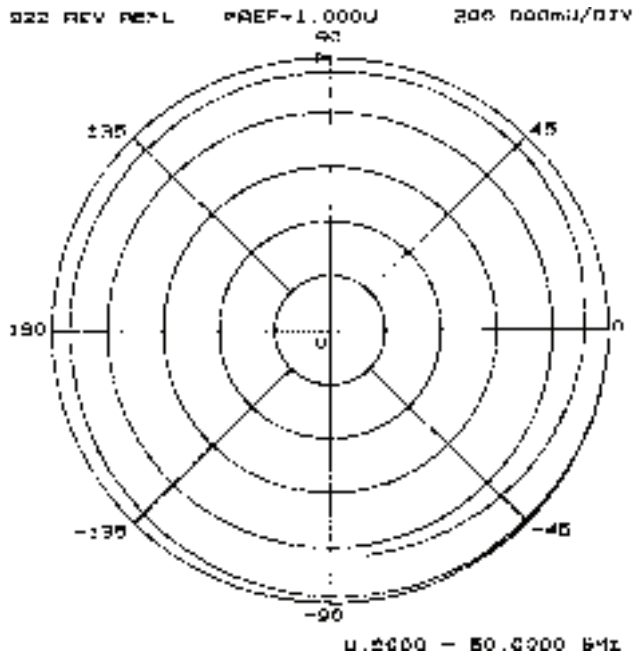

S11 FORWARD REFLECTION

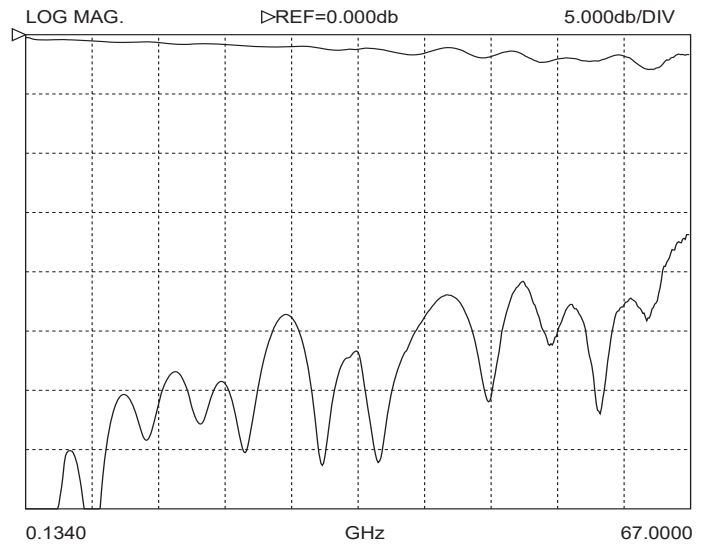

Typical uncalibrated performance of a Model 67A-GSG-150-P Picoprobe. The top trace is the round trip return loss into a short which is twice the probe's insertion loss. The bottom trace is the return loss into a 50 ohm load.

S12 REVERSE TRANSMISSION

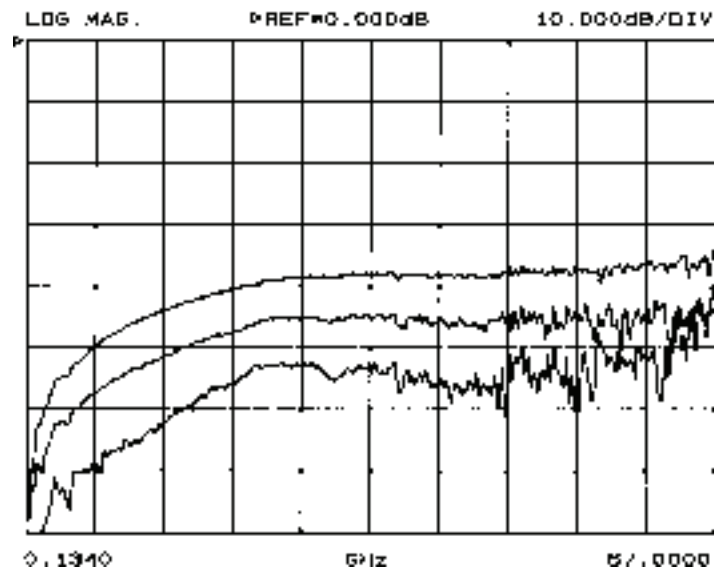

Crosstalk performance of two Model 67A-GSG-150-P Picoprobes while contacting a bare sapphire substrate with spacings of 100, 200, and 400 Microns.

LEFT: A linear-polar chart showing the calibrated response of a Model 67A-GSG-150-P while contacting a 10 pSec coplanar line. The LOST method was used for calibration.

ORDERING INFORMATION

When ordering Model 67A probes, use the following part numbering convention:

Model 67A- _____ - ____ - _____
 configuration - pitch - mounting style

Configuration: Specify GSG, GS or SG for tip placement where S is the signal tip and G is a ground tip. Use the following diagram to determine the appropriate configuration.

Top View

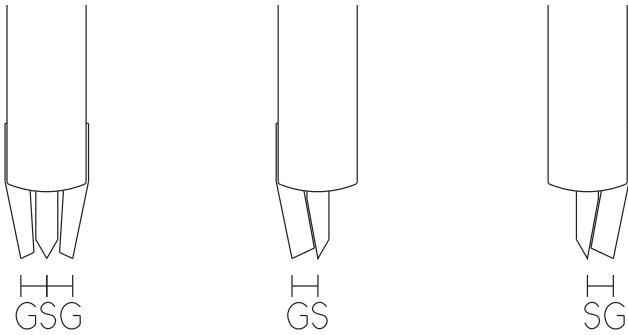

Pitch: Specify ground (G) to signal (S) tip spacing in Microns from 50 to 1250 microns. For standard GSG probes, the two spacings are equal. Contact the factory for spacings larger than 1250 microns or unusual tip placement and spacings.

Mounting Style: Specify T,C,GR,P,DP,EDP or LP. Choose the appropriate mounting type for your application. The P,DP,EDP and LP styles have the connector pointing back at a 45 degree angle to give more working area above the probe. The DP and EDP styles are used where extra clearance beneath the probe is needed. However, probe positioning is more difficult. Due to the increased probing angle, the probe points slide further forward for a given change in the Z axis than our other style probes. Custom mounting styles are available.

Example: A 67A-GSG-150-P is a Model 67A with Ground, Signal, Ground configuration with 150 microns between each contact mounted in a P style adaptor.
 Covered by US patent # 4,871,964

Mounting Styles and Dimensions

