

Picoprobe®

BY GGB INDUSTRIES INC.

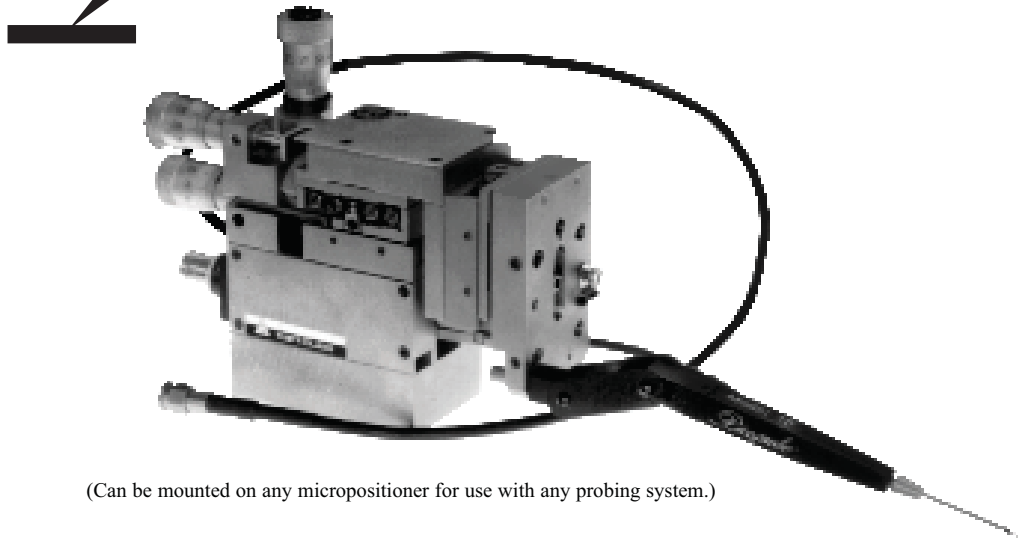

(Can be mounted on any micropositioner for use with any probing system.)

Picoprobe® Model 10 is a multipurpose, high speed, passive probe which can be used for driving as well as receiving signals. The Model 10 consists of a one meter length of flexible 50 Ω coaxial cable terminated by a carefully trimmed SMA connector on one end and by a miniature, high speed 50 Ω connector specially developed to receive Model 10 replaceable coaxial probe tips on the other. The 50 Ω coaxial cable was custom designed for the Model 10 to accommodate high speed signals, yet remain very flexible, so that moving the cable would not disturb the probe points.

Adaptable for a wide range of applications, the Model 10 uses a variety of special purpose, easily replaceable probe tips. Each probe tip consists of a 1.5 inch long 50 Ω semi-rigid coaxial line, a retaining nut, one or two probe points, and a variety of electrical components tailored to achieve the desired performance characteristics.

To drive or receive signals on 50 Ω circuit points, we recommend the Picoprobe® Model 10 be fitted with a probe tip that has two probe points, one for the ground and one for the signal. Probe points which extend 0.120 inches beyond the 50 Ω coaxial probe tip have been designed for dc to 3.5 GHz response and probe points which extend 0.030 inches beyond the probe tip have been designed for dc to 7 GHz response. The longer 0.120 inch tips are more flexible, making them more durable and easier to use than the shorter 0.030 inch style. To receive signals from high impedance circuit points, Model 10 probe tips with a 250 Ω , 500 Ω , or 5 k Ω input resistance should be used. The 250 Ω tip should be used with 0.180 inch long dual probe points to achieve dc to 10 GHz response. The signal will be attenuated by 5:1. The 500 Ω tip should be used either with 0.180 inch long dual probe points to achieve dc to 11 GHz response or with a 2 inch long ground strap to achieve dc to 4 GHz response. The signal will be attenuated by 10:1. The 5k Ω tip should be used either with 0.180 inch long dual probe points to achieve dc to 5 GHz response, a 2 inch ground strap to achieve dc to 4 GHz response, or a 6 inch ground strap to achieve dc to 2 GHz response. The signal will be attenuated by 100:1. To drive high impedance circuit points, Model 10 probe tips with a 50 Ω terminating resistor should be used. See chart below.

All Model 10 probe tips manufactured by GGB Industries, Inc. have been trimmed to compensate for cable loss and minimize the need for a short ground. Grounding methods would depend upon the desired frequency response and range from dual probe points to a 6 inch long flexible ground strap. In applications where many circuit points must be accessed and a ground is not conveniently located, a flexible ground strap can be substituted for the ground point.

<p>50 Ω Input Impedance Mode</p> <table border="0"> <tr> <td></td> <td style="text-align: center;">0.120"</td> <td style="text-align: center;">0.030"</td> </tr> <tr> <td>frequency response -</td> <td>dc to 3.5 GHz</td> <td>dc to 7 GHz</td> </tr> <tr> <td>insertion loss -</td> <td>3dB</td> <td>3db</td> </tr> <tr> <td>return loss -</td> <td>>10 dB</td> <td>>10 dB</td> </tr> <tr> <td>attenuation -</td> <td>1:1</td> <td>1:1</td> </tr> </table>		0.120"	0.030"	frequency response -	dc to 3.5 GHz	dc to 7 GHz	insertion loss -	3dB	3db	return loss -	>10 dB	>10 dB	attenuation -	1:1	1:1	<p>250 Ω Input Impedance Mode</p> <p>frequency response - dc to 10 GHz (-3 dB) attenuation - 5:1</p>
	0.120"	0.030"														
frequency response -	dc to 3.5 GHz	dc to 7 GHz														
insertion loss -	3dB	3db														
return loss -	>10 dB	>10 dB														
attenuation -	1:1	1:1														
<p>500 Ω Input Impedance Mode</p> <p>frequency response - dc to 11 GHz (-3 dB) attenuation - 10:1</p>	<p>5 KΩ Input Impedance Mode</p> <p>frequency response - dc to 5 GHz (+3 dB) attenuation - 100:1</p>															

Model 10 Picoprobe® Replacement Tips Part Number System

Model 10 tip part numbers can be determined by filling in the spaces above each column in this chart.

10						
Model Number	Added Resistance to 50 Ω Coaxial Tip	Outside diameter of probing wire	Probing wire material	No. of probing wires	Ground R / L	Space Between Points
	50/30 = No added resistance (50 Ω coax to 0.030" long probe tips) 50/120 = No added resistance (50 Ω coax to 0.120" long probe tips) 50T = 50 Ω resistor placed between center conductor and shield just before probe tips. 50C = a capacitor placed between center conductor and shield just before probe tips. (specify value) 250 = 250 Ω input resistance attenuates 5:1 500 = 500 Ω input resistance attenuates 10:1 1K = 1000 Ω input resistance attenuates 20:1 2.5K = 2500 Ω input resistance attenuates 50:1 5K = 5000 Ω input resistance attenuates 100:1	125 = 125 micron wire sharpened to approx. 5 microns for tungsten and 25 microns for Pd or BeCu 60 = 60 micron wire sharpened to approx. 3 microns for tungsten and 10 microns for Pd or BeCu 35 = 35 micron wire sharpened to approx. 2 microns (tungsten only) 22 = 22 micron wire sharpened to approx. 1 micron (tungsten only) 10 = 10 micron wire sharpened to approx. 0.2 micron (tungsten only)	W = Tungsten Pd = Palladium BeCu = Beryllium Copper	1 = one signal wire only 2 = one signal wire and one ground wire Note: If "1" is entered end part number here	R = Right L = Left Ground on Right or Left side of signal point as seen looking from front to back of Model 10	Spacing between signal and ground points (indicate distance in either inches or microns)

Example: 10-500-60-W-2-R-120 micron - Denotes a Model 10 probe tip with 500 Ω input resistance, 60 micron probing wires, one signal and one ground wire made of tungsten, the ground is on the right side of the signal wire, and the space between probe points is 120 microns.

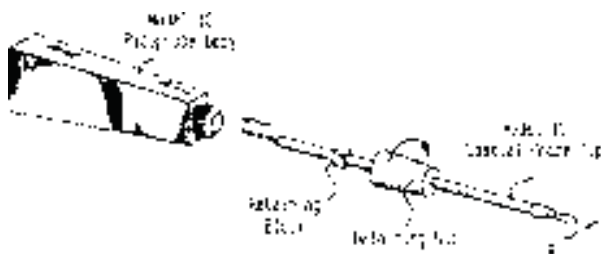



Model 40A

High Performance Microwave Probes

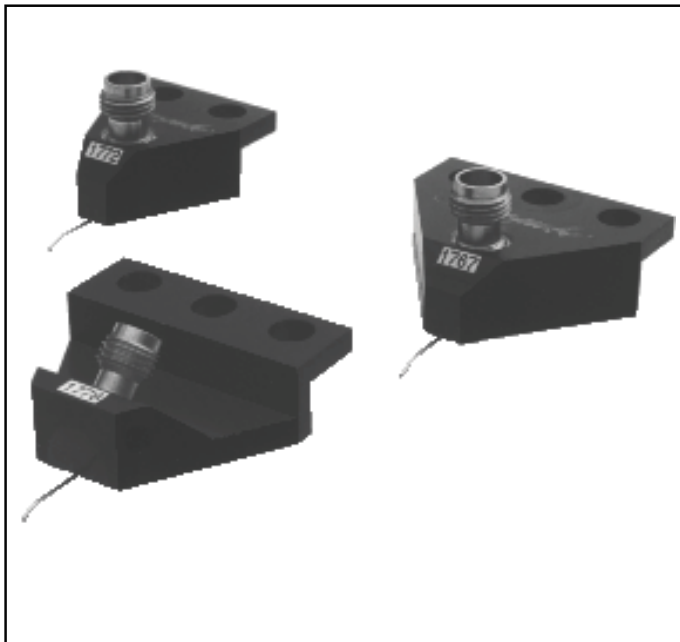

Model 40A probes mounted in three different adaptor styles

Features

- Durable
- DC to 40 GHz
- Insertion loss less than 0.8 db
- Return loss greater than 18 db
- Measurement repeatability -80 db
- Individually spring loaded contacts
- BeCu or Tungsten tips available
- Any pitch from 50 to 1250 microns
- Variety of Footprints
- Patented coaxial design

The GGB Industries, Inc., Model 40A Picoprobe® sets new standards in microwave probing performance. Using low loss coaxial techniques, the Model 40A achieves an insertion loss of less than 0.8 db and a return loss of greater than 18 db through 40 GHz.

With its individually spring loaded Beryllium-Copper or optional Tungsten tips, the Model 40A provides reliable contacts, even when probing non-planar

structures. This reliable low resistance contact is one of the keys to providing highly repeatable measurements. The Model 40A also provides direct viewing of the probe tips for accurate positioning.

The Model 40A can be mounted in various adaptors for use with standard microwave probe stations or attached to thin blades for use with dc probe needles on a probe card or multi-contact wedge. Custom mounts are available.

Any pitch (tip spacing) from 50 to 1250 microns may be specified. Probe pitches greater than 1250 microns can be accommodated. The probe can be configured with Ground-Signal-Ground (G,S,G), Ground-Signal (G,S), or Signal-Ground (S,G) tip footprints. We recommend smaller pitches with a G,S,G footprint for best performance.

Connection to the Model 40A is through a female K connector and is compatible with the 3.5 mm and SMA connectors.

Flexible Tips for Flexible Probing

Each Model 40A has patented, independently spring loaded tips which ensure a reliable contact to the probing surface. Because the tips are flexible they minimize circuit damage, increase probe life, and most importantly, provide a reliable individually spring loaded contact for each point. With a small amount of overdrive, the point scrubs the surface to make a reliable contact free of dust, dirt, and oxide contamination. The ability to view the exact contact area eases probe positioning and allows for the precise positioning necessary for good LRM calibrations. The flexible tips even allow probing of non-planar surfaces such as ceramic substrates and laser diode structures.

Coaxial Transmission Improves Performance

The Model 40A uses a precision miniature 50 ohm coaxial cable from the probe tips to the connector interface. The coaxial design provides lower loss and less radiation than coplanar designs. The miniature coaxial cable is fabricated from flexible Beryllium-Copper which greatly improves the probe's durability.

Probe Cards & Multi-Contact Wedges

Model 40A probes can be mounted on standard 4.5 inch probe cards, custom-sized cards, and our unique multi-contact wedge bodies to provide a convenient method for testing wafers at high frequencies using standard automatic or manual probe stations. Picoprobe Cards and Multi-Contact Wedges can be designed with 40, 50, 67, and/or 110 GHz probes for RF connections with DC needles for power and low frequency signals.

An Entire Line of Microwave Probes

For special applications, the Model 40A can be mounted in custom adaptors, the coaxial line can be bent to fit tight spaces, and the tips can be configured to match extremely non-planar surfaces or non-symmetrically placed grounds. Other options include: Tungsten probe tips; a high temperature version (40A-HT); and an integrated series or terminating resistor built into the signal tip. Many other types are available, please call.

For applications above 40 GHz, GGB Industries, Inc., offers the Model 50A, Model 67A, and Model 110A/H for DC to 110GHz applications.

Several models are available with wave guide inputs including the Model 50, Model 75, Model 90, Model 120, Model 140, and Model 220. The wave guide probes have an optional integral bias T for active device measurements.

Probing Expertise

GGB Industries, Inc., has broad capabilities in custom probe engineering and manufacturing and our staff is accustomed to creating unique solutions for the most difficult probing requirements. GGB Industries, Inc., is the leading supplier of high impedance active probes offering models with input capacitances of as low as .02 pF and frequency responses of up to 3.0 GHz.

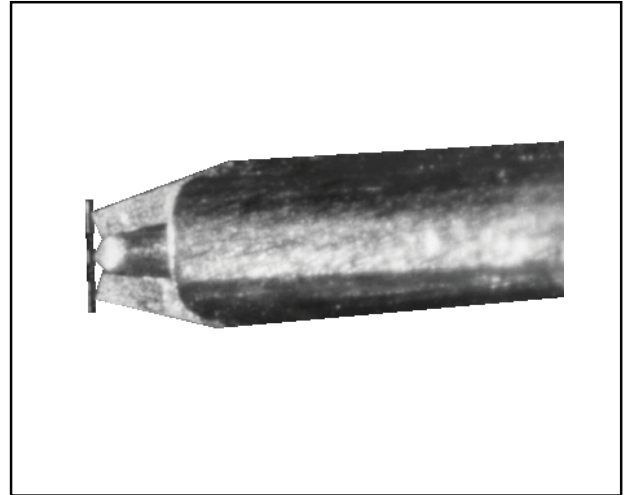

Closeup of Model 40A Tips with 150 Micron pitch almost touching a 50 Ω calibration load.

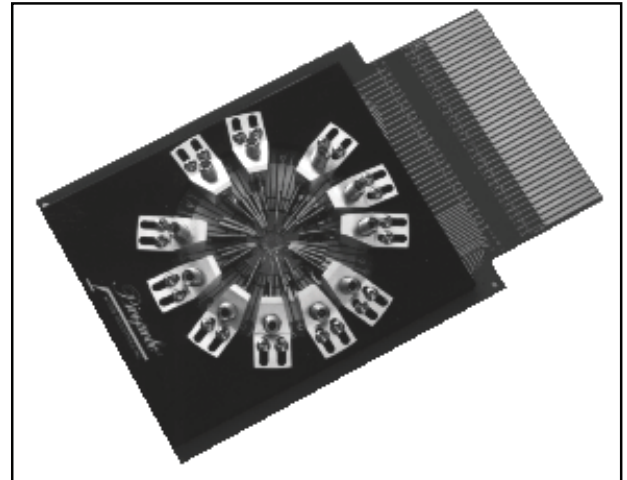

Typical Probe Card with Model 40A Probes

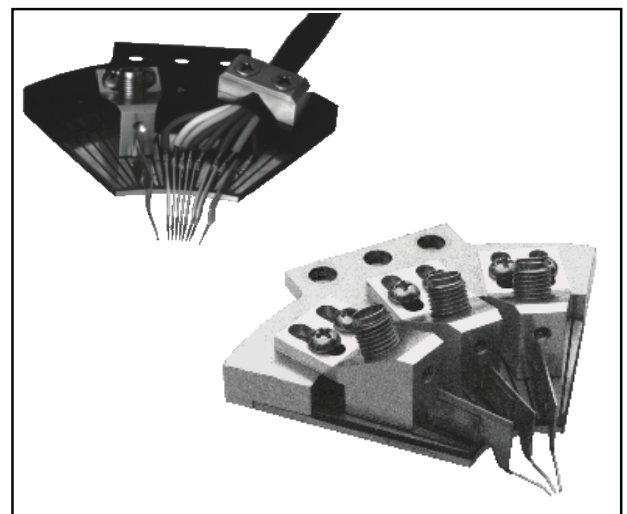

Examples of the Multi-Contact Wedge which combine Multiple RF and DC contacts .

Model 40A Performance Data¹ G,S,G Configuration

Frequency Range:	DC to 40 GHz
Insertion Loss:	Less than 1.0 db to 40 GHz (.70 db typical)
Return Loss:	Less than 30 db to 4 GHz (35 db typical) Less than 20 db to 26 GHz (23 db typical) Less than 18 db to 40 GHz (20 db typical)
Crosstalk²:	Less than 38 db to 40 GHz

¹ Specifications are for the P-style Model 40A Picoprobes with G,S,G configurations and pitches of between 50 and 300 microns. The C and T style Model 40A Picoprobes (see following page for mounting styles) have the same specifications except for insertion loss, which is less than 1.2 db (0.9 db typical).

² Crosstalk is measured using two probes contacting a bare sapphire substrate 100 microns apart.

Model 40A Performance Data³ G,S and S,G Configuration

Frequency Range:	DC to 40 GHz
Insertion Loss:	Less than 2.0 db to 40 GHz (1.6 db typical)
Return Loss:	Less than 30 db to 4 GHz Less than 15 db to 26 GHz Less than 12 db to 40 GHz

³ Specifications are for the P-style Model 40A Picoprobes

S₁₁ Z
REF 1.0 Units
200.0mUnits/

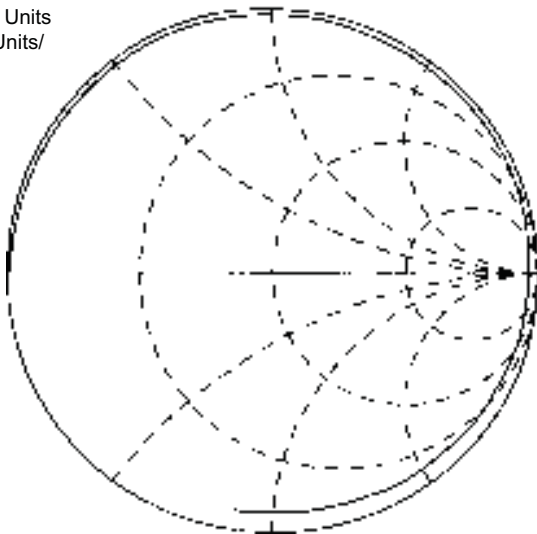

START 0.045000000 GHz
STOP 40.000000000 GHz

S11 FORWARD REFLECTION

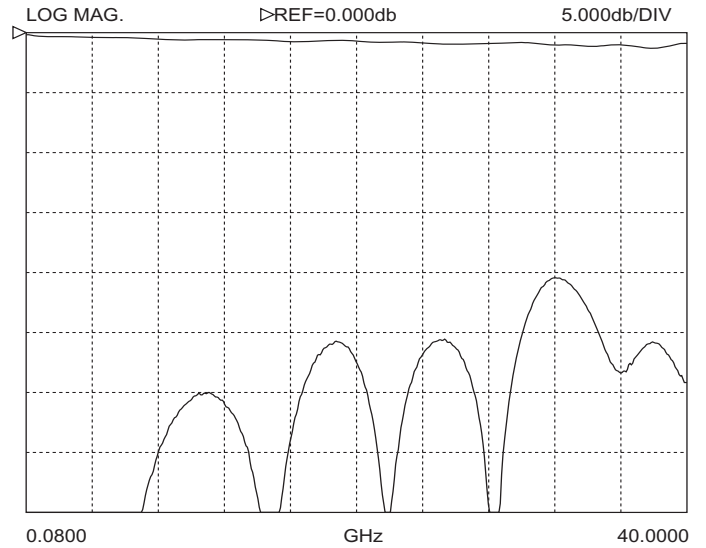

Typical uncalibrated performance of a Model 40A-GSG-150-P Picoprobe. The top trace is the round trip return loss into a short which is twice the probe's insertion loss. The bottom trace is the return loss into a 50 ohm load.

S12 FORWARD TRANSMISSION

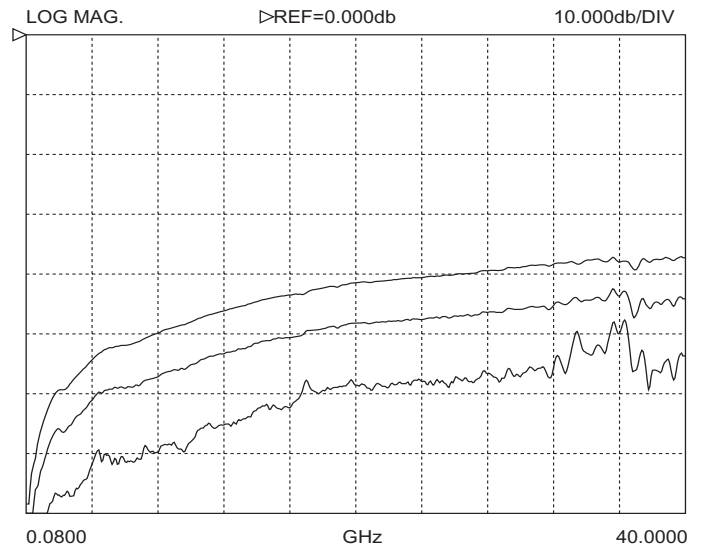

Crosstalk performance of two Model 40A-GSG-150-P Picoprobes while contacting a bare sapphire substrate with spacings of 100, 200, and 400 Microns.

LEFT: A Smith Chart showing the calibrated response of a Model 40A-GSG-150-P while contacting a coplanar offset short. The LRM method was used for calibration.

ORDERING INFORMATION

When ordering Model 40A probes, use the following part numbering convention:

Model 40A- _____ - ____ - _____
 configuration - pitch - mounting style

Configuration: Specify GSG, GS, or SG for tip placement where S is the signal tip and G is a ground tip. Use the following diagram to determine the appropriate configuration.

Top View

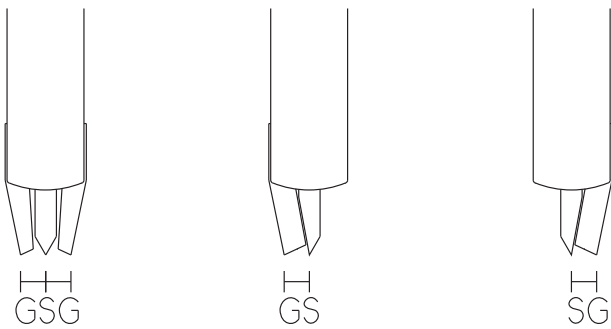

Pitch: Specify ground (G) to signal (S) tip spacing in Microns from 50 to 1250 microns. For standard GSG probes, the two spacings are equal. Contact the factory for spacings larger than 1250 microns or unusual tip placement and spacings.

Mounting Style: Choose from thirteen adapter styles. Seven of the most common adapter styles are pictured on the right. Specify T, C, GR, P, DP, EDP, LP, Q, F, S, DS, VP, or RVP. Choose the appropriate mounting type for your application. The P, DP, EDP, LP, Q, S, DS, VP, and RVP styles have the connector pointing back at a 45 degree angle to give more working area above the probe. The DP, EDP, DS, VP, and RVP styles are used where extra clearance beneath the probe is needed. When using DP, EDP, and DS style probes, probe positioning is more difficult due to the increased probing angle since the probe points slide further forward for a given change in the Z axis than our other style probes. Custom mounting styles are available.

Example: A 40A-GSG-150-P is a Model 40A with Ground, Signal, Ground configuration with 150 microns between each contact mounted in a P style adaptor.

Right: Specifications for seven of our most common adapter styles. Please contact our office or visit our web site at: www.picoprobe.com for information on other adapter styles.

Covered by US patent # 4,871,964

Mounting Styles and Dimensions

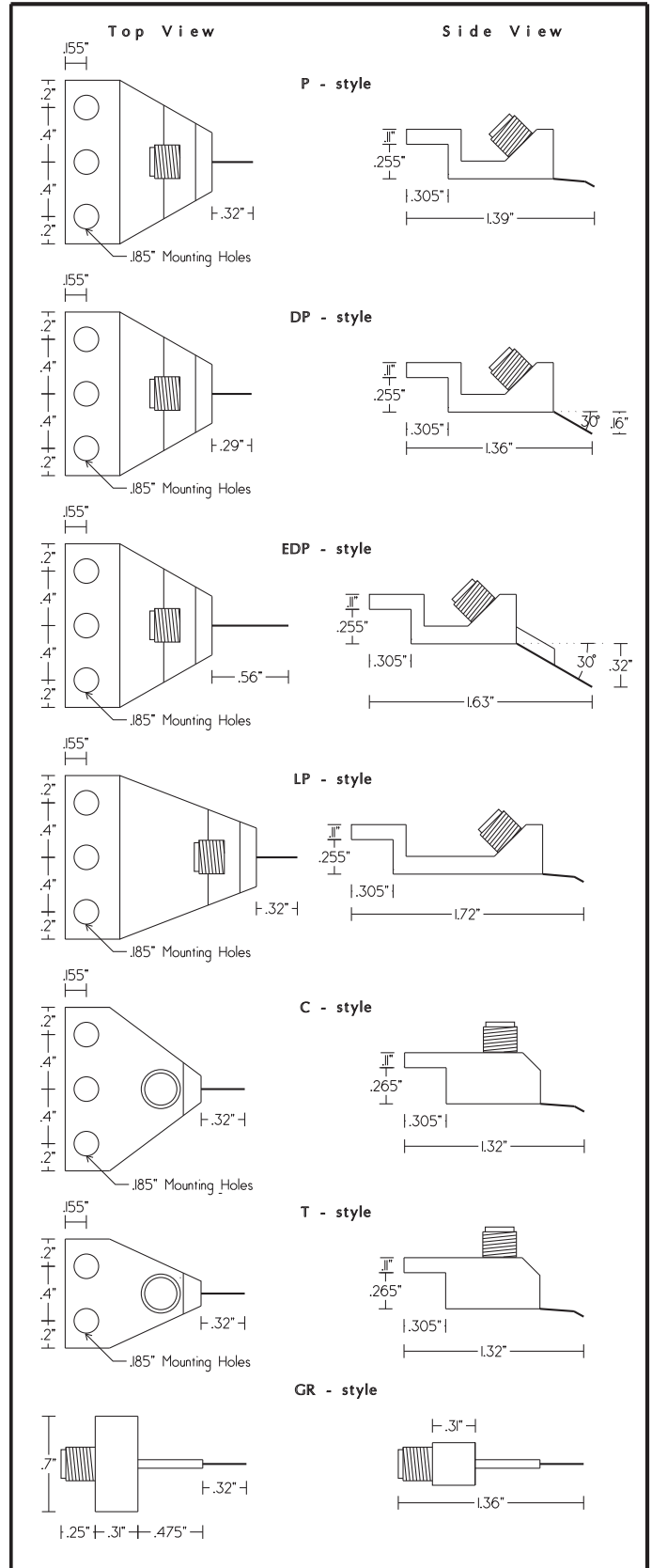

**Even lower loss than
"the lowest loss probe in the industry"**

Picoprobe®

BY GGB INDUSTRIES INC.

Model 40M

High Performance Microwave Probes



We have shaved another .25 db insertion loss off of our industry standard Model 40A Picoprobe®. This probe is recommended for certain types of load pull and noise parameter measurements when even our standard, super low, 0.75 db insertion loss (typical at 40 GHz) is too high.

Features of 40M-GSG-xxx-PLL

- **Durable**
- **DC to 40 GHz**
- **Insertion loss less than 0.5 db**
- **Return loss greater than 20db**
- **Measurement repeatability -52db**
- **Individually spring loaded contacts**
- **Variety of Footprints**
- **Patented coaxial design**

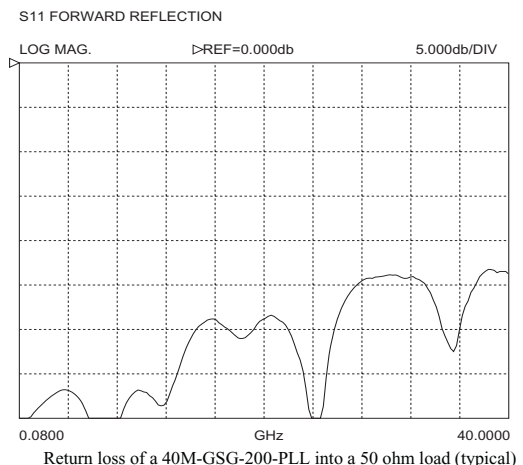
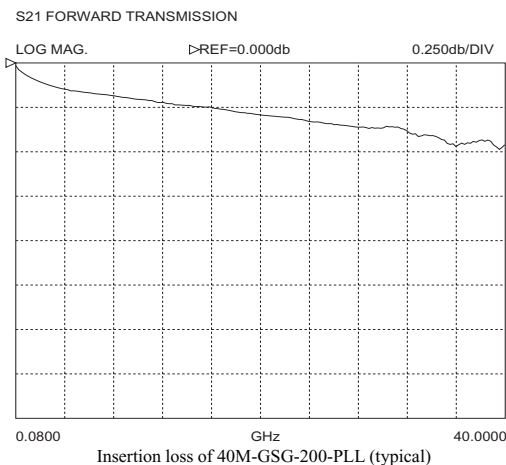

Picoprobe®

BY GGB INDUSTRIES INC.

Model 50

High Performance Microwave Probes



Model 50 Picoprobe® with bias T

The Model 50 Picoprobe® sets new standards in microwave probing performance. Benefiting from coaxial techniques, which have inherent low loss and low dispersion characteristics, the Model 50 Picoprobe®, with or without the bias T option, achieves an insertion loss of less than 0.8 db (typical) and a return loss of greater than 15 db (max.) over its frequency range.

With its individually spring loaded, Beryllium-Copper tips, the Model 50 Picoprobe® provides reliable contacts, even when probing non-planar structures. This reliable low resistance contact is one of the keys to providing highly repeatable measurements (-55 db) at V band frequencies. The Model 50 Picoprobe® also provides direct viewing of the probe tips for accurate positioning.

Any pitch (tip spacing) from 50 microns and up may be specified. The probe can be configured with Ground-Signal-Ground (G,S,G), Ground-Signal (G,S), or Signal-Ground (S,G) tip footprints. We recommend smaller pitches with a G,S,G footprint for best performance.

Features

- **Durable**
- **33 GHz to 50 GHz**
- **Insertion loss 1.0 db max.**
- **Return loss 15 db max.**
- **Individually spring loaded contacts**
- **Measurement repeatability -55 db**
- **Bias T option available**
- **Patented coaxial design**

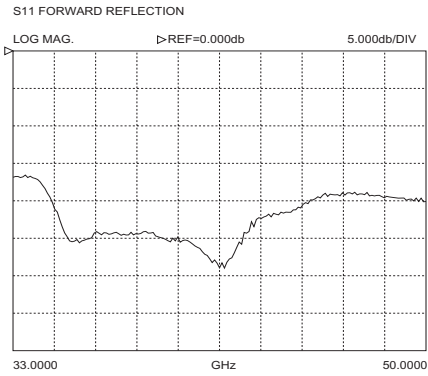

Typical uncalibrated performance of a Model 50-GSG-100-BT while touching a 50 ohm load on our CS-5 calibration substrate.

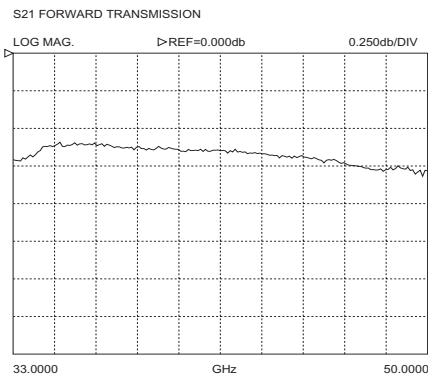

Typical insertion loss of a Model 50-GSG-100-BT

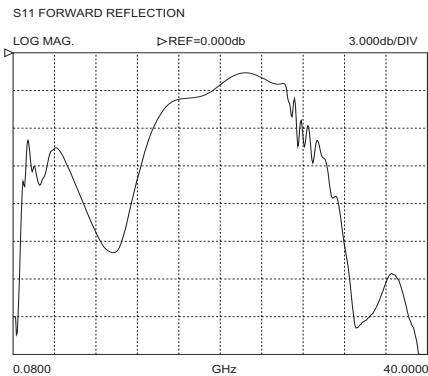

The Model 50 Picoprobe[®] bias T provides a direct low resistance DC path for supplying up to 1.5 A to a device under test. The bias T also has special circuits which add loss at frequencies below the cut off frequency (26.34 GHz) of WR-22 waveguide. This data was taken by launching a, 40 MHz to 50 GHz, signal from the tips of a calibrated Model 67A into the tips of a Model 50-GSG-150-BT. Without this low frequency loss, most active devices will oscillate.

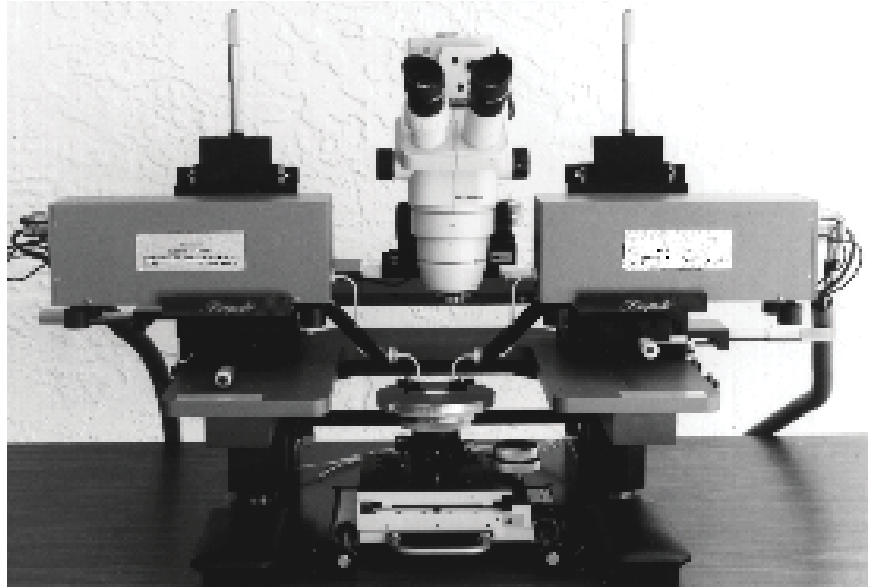

Micropositioners are available to hold Wiltron V band modules so that the module and the probe are micropositioned as a unit. In this way, total ease of positioning can be achieved with minimum insertion loss.

The probes also have a 3 hole mounting adaptor which will fit standard microwave probe stations. In this case, a longer section of waveguide may be desired to add positioning flexibility.

Picoprobe®

BY GGB INDUSTRIES INC.

Model 67A

High Performance Microwave Probes

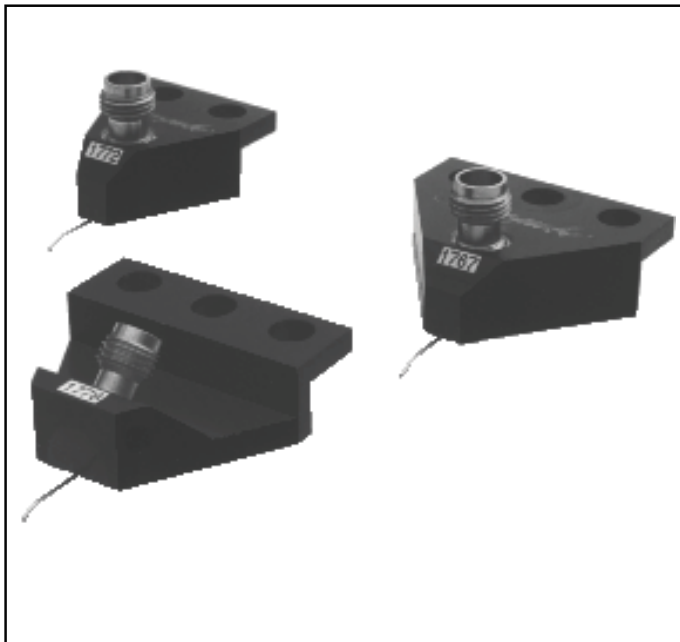

Model 67A probes mounted in three different adaptor styles

The GGB Industries Model 67A probe sets new standards in microwave probing performance. Using low loss coaxial techniques, the Model 67A achieves an insertion loss of less than 1.1 db and a return loss of greater than 14 db through 67 GHz

With its individually spring loaded, Beryllium-Copper tips, the Model 67A provides reliable contacts, even when probing

non-planar structures. This reliable low resistance contact is one of the keys to providing highly repeatable measurements. The Model 67A also provides direct viewing of the probe tips for accurate positioning.

The Model 67A can be mounted in various adaptors for use with standard microwave probe stations. Custom mounts are available.

Any pitch (tip spacing) from 50 to 1250 microns may be specified. The probe can be configured with Ground-Signal-Ground (G,S,G), Ground-Signal (G,S), or Signal-Ground (S,G) tip footprints. We recommend smaller pitches with a G,S,G footprint for best performance.

Connection to the Model 67A is through a female 1.85 mm V connector. (2.4 mm compatible)

Features

- Durable
- DC to 67 GHz
- Insertion loss less than 1.1 db
- Return loss greater than 14 db
- Measurement repeatability -50 db
- Individually spring loaded contacts
- BeCu or Tungsten tips available
- Any pitch from 50 to 1250 microns
- Variety of Footprints
- Patented coaxial design

Flexible Tips for Flexible Probing

Each Model 67A has patented, independently spring loaded tips which make contact to the probing surface. Because the tips are flexible they minimize circuit damage, increase probe life, and most importantly, provide a reliable individually spring loaded contact for each point. With a small amount of overdrive, the point scrubs the surface to make a reliable contact free of dust, dirt, and oxide contamination. The ability to view the exact contact area eases probe positioning and allows for the precise positioning necessary for good LRM calibrations. The flexible tips even allow probing of non-planar surfaces such as ceramic substrates and laser diode structures.

Coaxial Transmission Improves Performance

The Model 67A uses a precision miniature 50 ohm coaxial cable from the probe tips to the connector interface. The coaxial design provides lower loss and less radiation than coplanar designs. The miniature coaxial cable is fabricated from flexible Beryllium-Copper which greatly improves the probe's durability.

Probe Cards

Model 40A probes can be mounted on standard 4.5 inch probe cards to provide a convenient method for testing wafers at high frequencies using standard automatic or manual probe stations. Picoprobe Cards combine our Model 40A probes for RF connections with DC needles for power and low frequency signals.

Line of Microwave Probes

Other models of Microwave probes are available with standard tip spacings of up to 1250 microns. Larger spacings are possible. For special applications, the Model 67A can be mounted in custom adaptors, the coaxial line can be bent to fit tight spaces, and the tips can be configured to match extremely non-planar surfaces or non-symmetrically placed grounds.

Three models are available with wave guide inputs. WR-22 for 33 to 50 GHz, WR-15 for 50 to 75 GHz, and WR-10 for 75 to 110 GHz. The wave guide probes have an integral bias T for active device measurements.

For applications below 40 GHz, GGB Industries offers the Model 40A Picoprobe which uses the 2.95mm K connector. The Model 40A performs up to 40 GHz with less than 1.0 db (0.7 db typical) insertion loss and return loss of greater than 18 db.

Many other types are available, please call.

Probing Expertise

GGB Industries is the leading supplier of high impedance active probes offering models with input capacitances of as low as .02 pF and frequency responses of up to 3.0 GHz. With 22 years of probing experience, GGB Industries has broad capabilities in custom probe engineering.

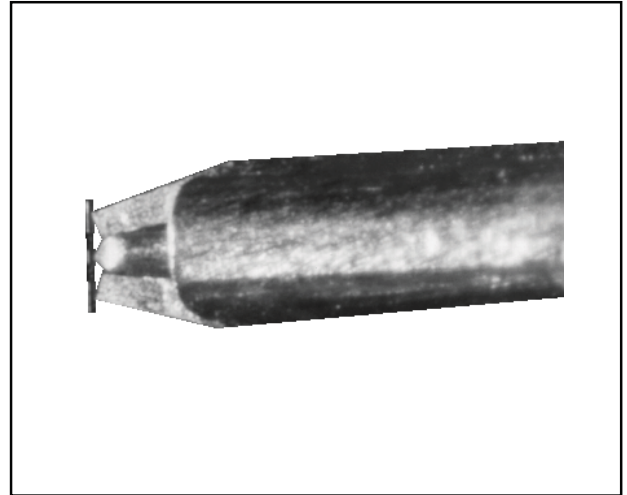

Closeup of Model 67A Tips with 150 Micron Pitch almost touching a 50 Ω calibration load.

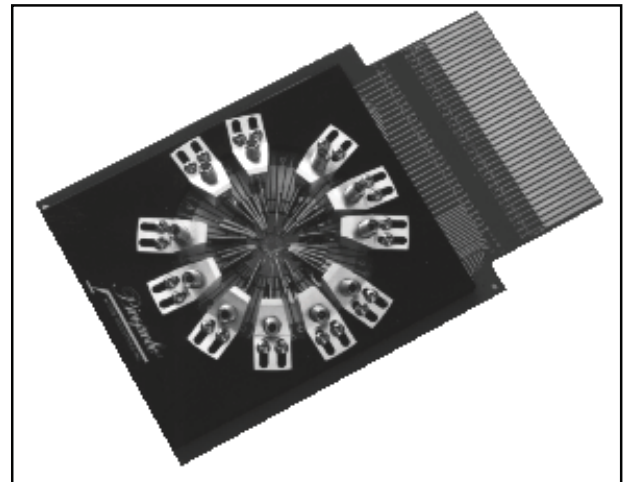

Typical Probe Card with Model 40A Probes

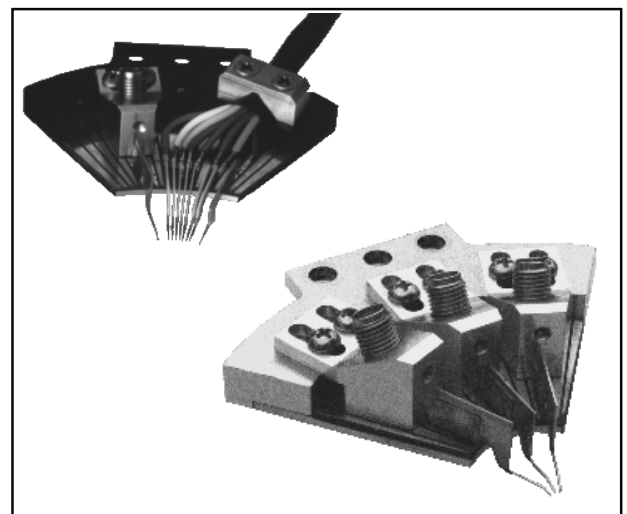

Examples of the Multi-Contact Wedge which combine Multiple RF and DC contacts .

Model 67A Performance Data¹ G,S,G Configuration

Frequency Range:	DC to 67 GHz
Insertion Loss:	Less than 1.1 db to 67 GHz (.95 db typical)
Return Loss:	Less than 35 db to 4 GHz (35 db typical) Less than 20 db to 26 GHz (23 db typical) Less than 18 db to 40 GHz (20 db typical) Less than 14 db to 67 GHz (16 db typical)
Crosstalk²:	Less than 35 db to 67 GHz

¹ Specifications are for the P-style Model 67A Picoprobes with G,S,G configurations and pitches of between 50 and 250 microns. The C and T style Model 67A Picoprobes (see following page for mounting styles) have the same specifications except for insertion loss, which is less than 1.3 db (1.2 db typical).

² Crosstalk is measured using two probes contacting a bare sapphire substrate 100 microns apart.

Model 67A Performance Data³ G,S and S,G Configuration

Frequency Range:	DC to 67 GHz
Insertion Loss:	Less than 1.0 db to 40 GHz (0.9 db typical)
Return Loss:	Less than 30 db to 4 GHz Less than 15 db to 26 GHz Less than 12 db to 40 GHz

³ Specifications are for the P-style Model 67A Picoprobes

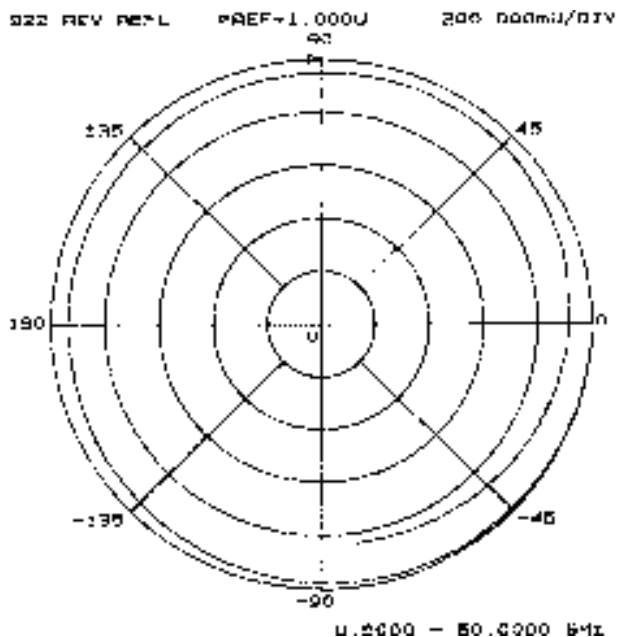

S11 FORWARD REFLECTION

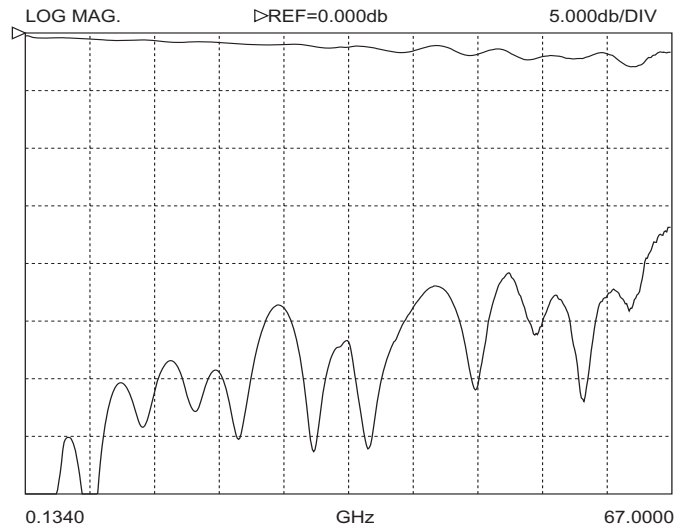

Typical uncalibrated performance of a Model 67A-GSG-150-P Picoprobe. The top trace is the round trip return loss into a short which is twice the probe's insertion loss. The bottom trace is the return loss into a 50 ohm load.

S12 REVERSE TRANSMISSION

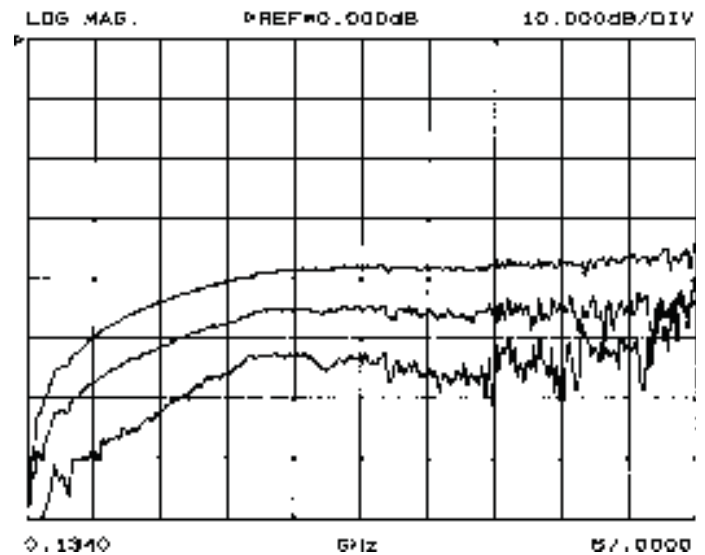

Crosstalk performance of two Model 67A-GSG-150-P Picoprobes while contacting a bare sapphire substrate with spacings of 100, 200, and 400 Microns.

LEFT: A linear-polar chart showing the calibrated response of a Model 67A-GSG-150-P while contacting a 10 pSec coplanar line. The LOST method was used for calibration.

ORDERING INFORMATION

When ordering Model 67A probes, use the following part numbering convention:

Model 67A- _____ - ____ - _____
 configuration - pitch - mounting style

Configuration: Specify GSG, GS or SG for tip placement where S is the signal tip and G is a ground tip. Use the following diagram to determine the appropriate configuration.

Top View

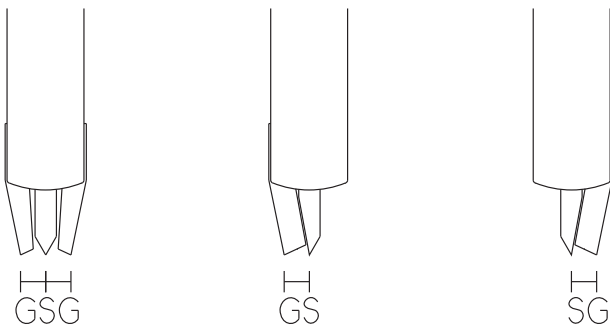

Pitch: Specify ground (G) to signal (S) tip spacing in Microns from 50 to 1250 microns. For standard GSG probes, the two spacings are equal. Contact the factory for spacings larger than 1250 microns or unusual tip placement and spacings.

Mounting Style: Specify T,C,GR,P,DP,EDP or LP. Choose the appropriate mounting type for your application. The P,DP,EDP and LP styles have the connector pointing back at a 45 degree angle to give more working area above the probe. The DP and EDP styles are used where extra clearance beneath the probe is needed. However, probe positioning is more difficult. Due to the increased probing angle, the probe points slide further forward for a given change in the Z axis than our other style probes. Custom mounting styles are available.

Example: A 67A-GSG-150-P is a Model 67A with Ground, Signal, Ground configuration with 150 microns between each contact mounted in a P style adaptor.

Covered by US patent # 4,871,964

Mounting Styles and Dimensions

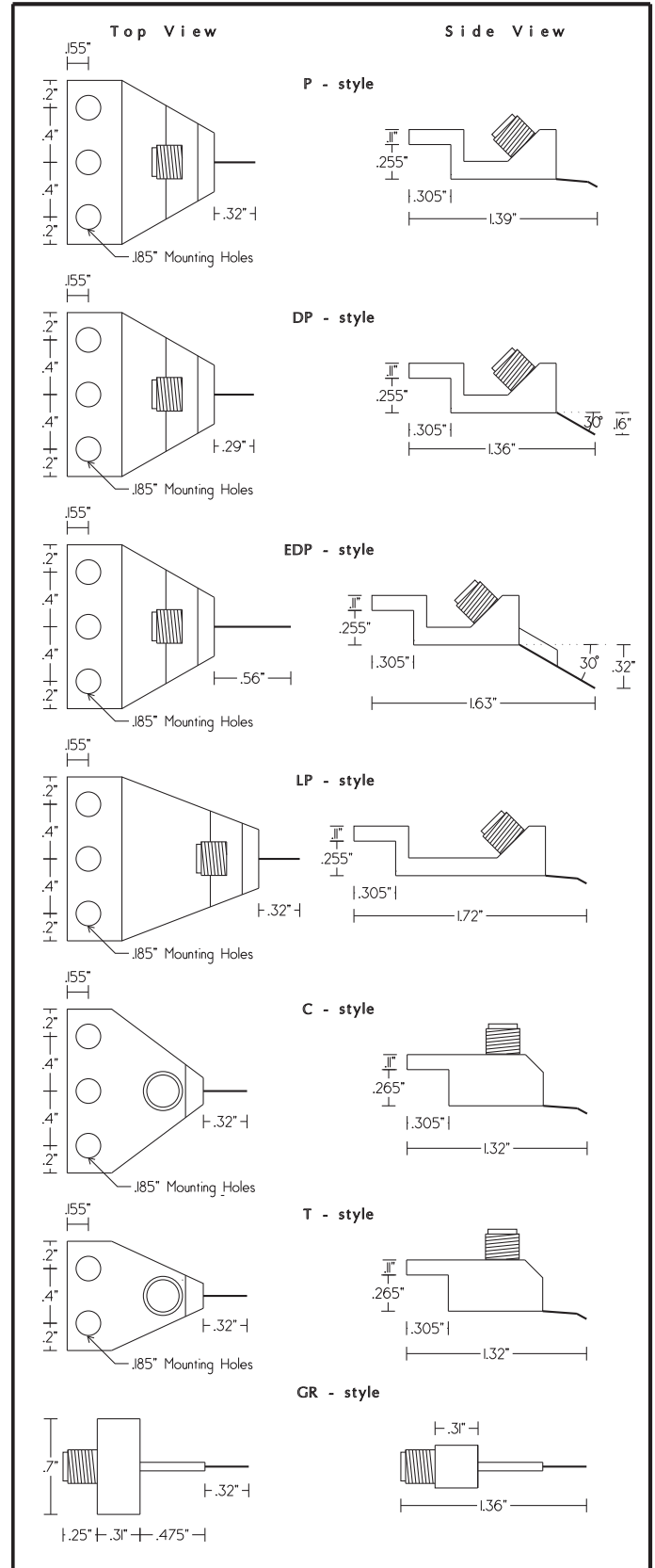

Picoprobe®

BY GGB INDUSTRIES INC.

Model 110H High Performance Microwave Probes



Model 110H Picoprobe® with female 1.0 mm connector

The Model 110H Picoprobe which incorporates our patented coaxial design techniques, has inherent low loss and low dispersion characteristics. Through its unique design, the Model 110H Picoprobe achieves an insertion loss of less than 1.5 dB and a return loss of greater than 15 dB over its frequency range.

With individually spring loaded, Beryllium-Copper tips, the Model 110H provide reliable contacts, even when probing

non-planar structures. This reliable low resistance contact is one of the keys to providing highly repeatable measurements at W band frequencies.

Like all of our Picoprobes, the Model 110H allow direct viewing of the probe tips for accurate positioning.

Any pitch (tip spacing) from 50 to 1250 microns may be specified. The probe can be configured with Ground-Signal-Ground

(G,S,G), Ground-Signal (G,S), or Signal-Ground (S,G) tip footprints. We recommend smaller pitches with a G,S,G footprint for best performance.

The Model 110H utilizes a female 1.0mm connector.

Features

- Durable
- DC to 110 GHz
- Insertion loss 1.5 dB max.
- Return loss 15 dB max.
- Individually spring loaded contacts
- Measurement repeatability -80 dB
- Patented coaxial design
- Available with a 1.0 mm connector

Picoprobe® Model 110H Performance Data



Model 110H Picoprobe®

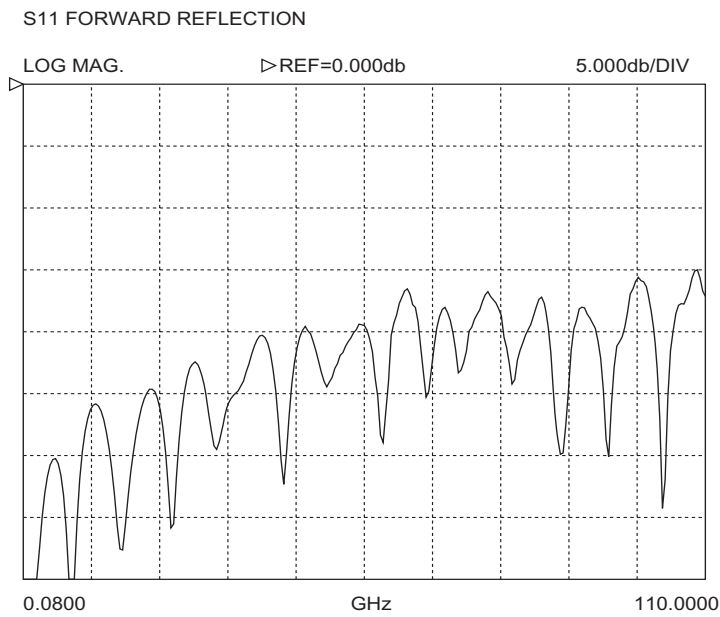

Left: Typical uncalibrated performance of a Model 110H-GSG-100-P while touching a 50 Ohm load on our CS-5 Calibration Substrate.

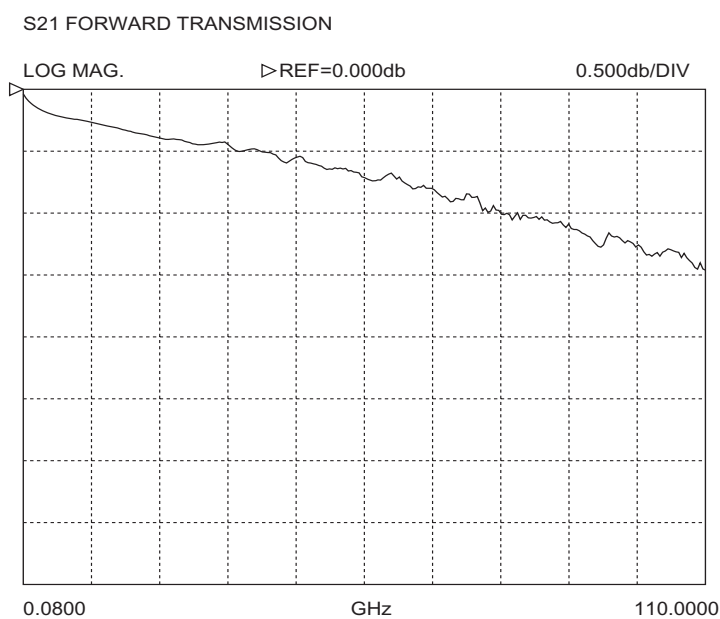

Left: Typical insertion loss of a Model 110H-GSG-100-P.

Picoprobe®

BY GGB INDUSTRIES INC.

Multi-Contact Wedge



An example of the Picoprobe® Multi-Contact Wedge with three 40 GHz probes and five dc needles.

Features

- **Durable**
- **DC to 40, 50, 67 or 110 GHz**
- **Mix RF and DC Contacts**
- **Up to 9 RF probes per side**
- **For MMIC or Module probing**
- **Individually spring loaded contacts**
- **Inexpensive, fast, custom fabrication**
- **Each wedge custom made to your layout**
- **Patented coaxial design**

The GGB Industries Multi-Contact Wedge allows for more chip design flexibility because it is custom configured to your circuit. Four Wedges can be used at the same time to probe a complete chip.

With its individually spring loaded, Beryllium-Copper tips, the Multi-Contact Wedge provides reliable contacts, even when probing non-planar structures. This reliable low resistance contact is one of the keys to providing highly repeatable measurements. The Multi-Contact Wedge also provides direct viewing of the probe tips for accurate positioning. When used

with standard microwave probe stations the Wedges can first be positioned to any microwave calibration standard and then moved into position on the MMIC or module to be tested.

The probe points on a Wedge can even be set to different depths so that multi-level modules can be successfully probed. Any pitch (tip spacing) from 50 to 1250 microns may be specified. Larger pitch probes are available by special order. The probes can be configured with Ground-Signal-Ground (G,S,G), Ground-Signal (G,S), or Signal-Ground (S,G) tip footprints.

Connection to the Model 40A Picoprobe is through a female K connector and is compatible with SMA and 3.5mm connectors. Connection to the Model 50A is via a female 2.4mm connector. Connection to the Model 67A is through a female V connector and is compatible with the 2.4mm connector. The 110H uses a 1.0mm connector.

Many other Multi-Contact Wedge designs are available, please refer to additional data sheets at: www.Picoprobe.com.

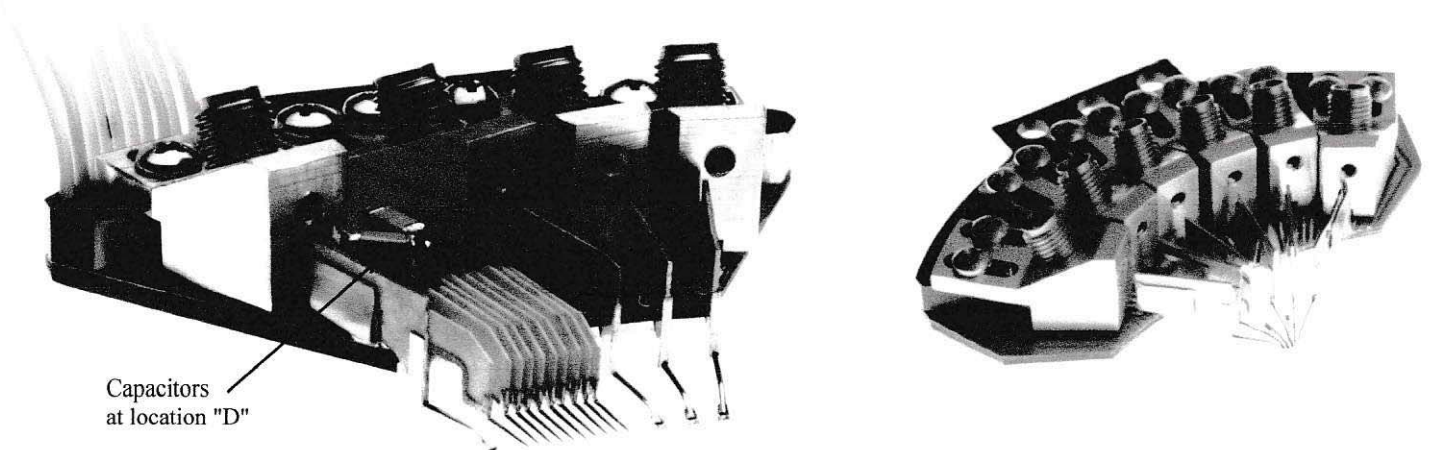

Two examples of the Picoprobe® Multi-Contact Wedge

Many different wiring configurations are available for the dc, power supply, or medium frequency needs. Ribbon cable, twisted pair, coaxial cable, and 22 AWG hook up wire are some of the types available. Our standard connectors include: flat cable-based connectors, banana plugs, BNC connectors, SMA connectors, (9, 15, 25, or 37 pin) D-Subminiature connectors, and 8, 14, 20, or 26 pin Post Headers and receptacles. The Post Headers have a double row of 0.025 inch pins on 0.1 inch centers. Many other connectors can be specified.

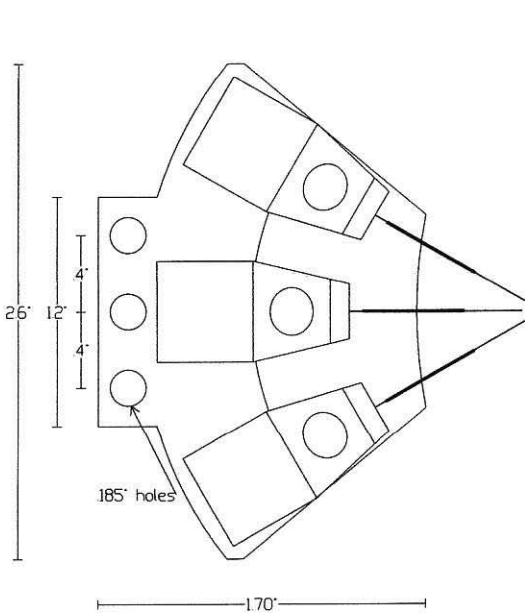
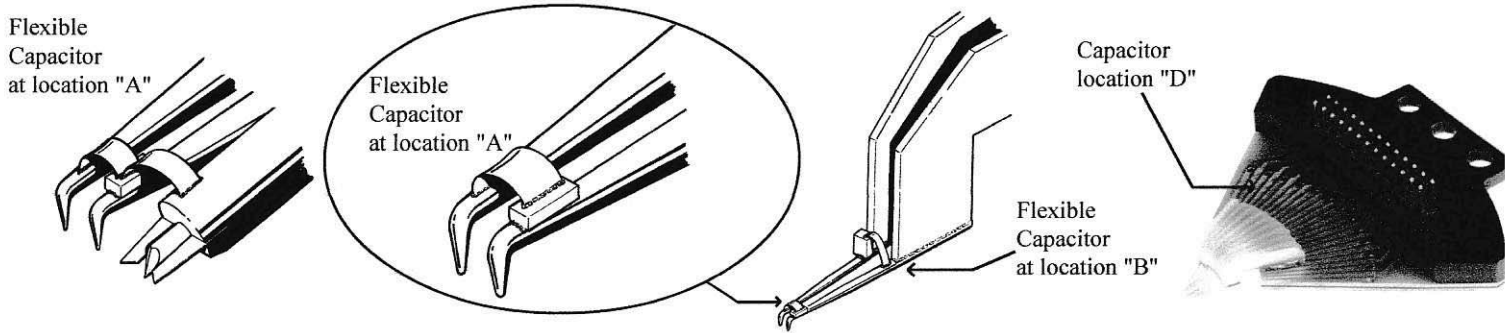

80 degree Multi-Contact Wedge

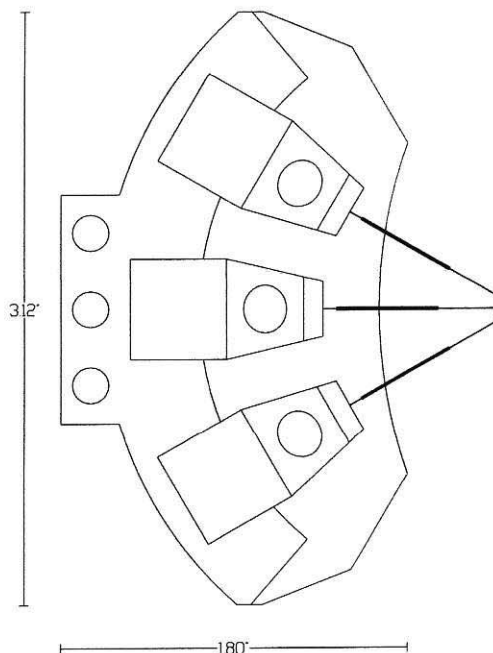

120 degree Multi-Contact Wedge

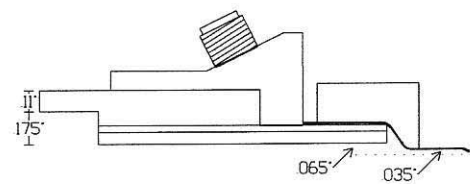

Multi-Contact Wedge Profile

Covered by US patent # 4,871,964



DC Multi-Contact Wedge

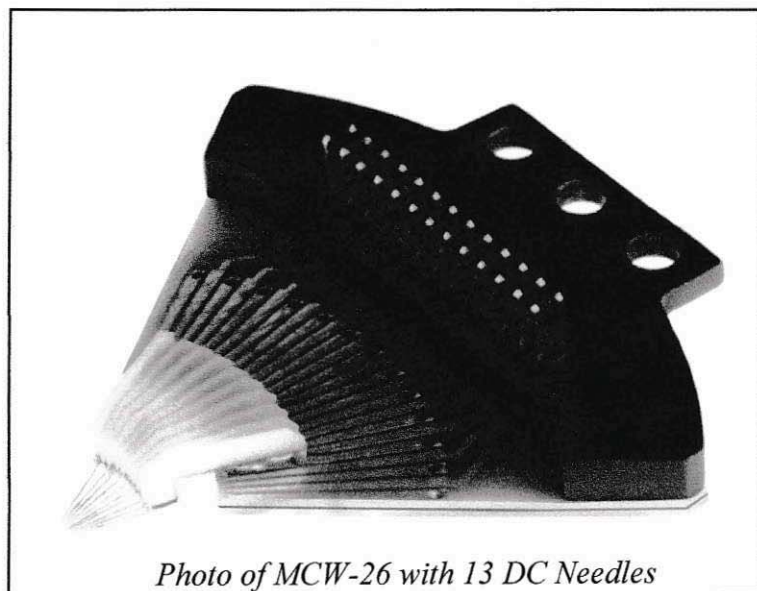

Photo of MCW-26 with 13 DC Needles

The DC Multi-Contact Wedge Series by GGB Industries, Inc., is a flexible alternative to providing either dc or power to a circuit for testing purposes. Each wedge is custom fabricated to your circuit layout and offers three alternative locations for capacitors, direct viewing of probe needles for accurate positioning, and can be configured with either a 14 pin, 20 pin, or 26 pin connector. The connector consists of a dual row of 0.025 inch square pins on 0.1 inch centers, providing the user with a highly flexible and useful tie-in point.

Probe needles on the DC Multi-Contact Wedge can be set to different depths so that multi-level modules can be successfully probed.

Features

- Durable
- Up to 26 DC probe needles
- Contacts are a dual row of 0.025 inch square pins on 0.1 inch centers
- Direct viewing of probe needles
- 3 Capacitor bypass locations available
- Inexpensive, fast, custom fabrication
- Each wedge custom made to your layout

The unique design of the DC Multi-Contact Wedge Series ensures reliable contacts, even when probing non-planar structures and allows for easy positioning when used with any standard microwave probe station.

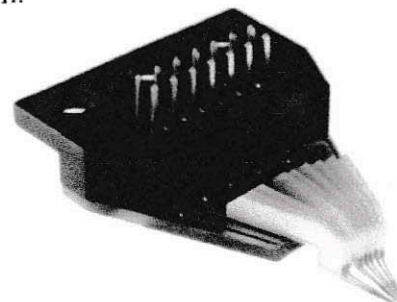

A MCW-14 configured with 9 DC needles.

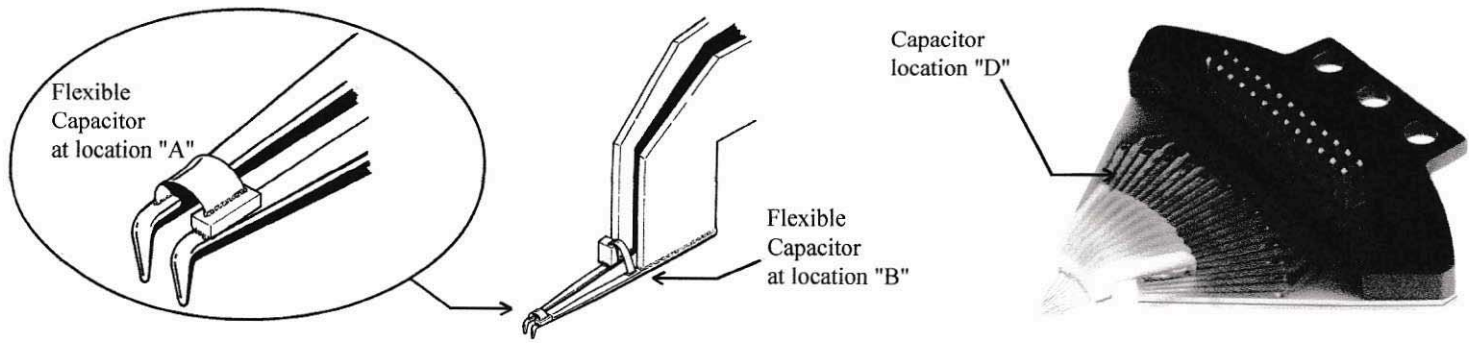

Bypass capacitors for the power supply pins are available in three different locations ("A", "B", and "D") using a process patented by GGB Industries, Inc.

DC Multi-Contact Wedge Series Dimensions

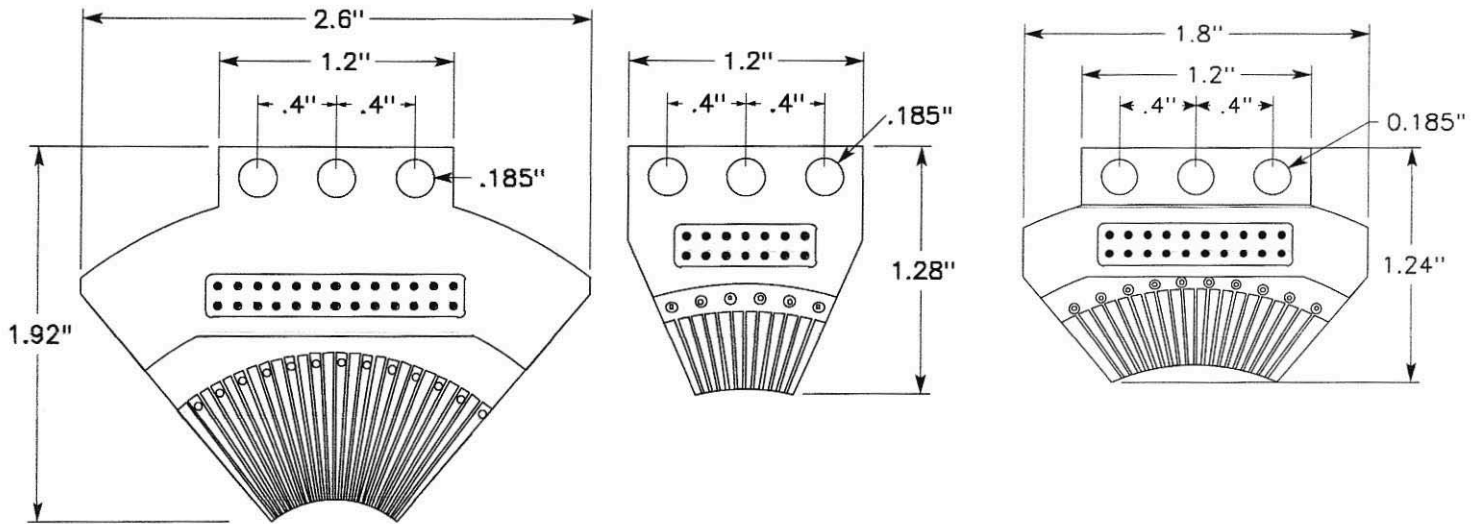

Contacts are a dual row of 0.025 inch square pins on 0.1 inch centers.

Additional Multi-Contact Wedge configurations not shown here are also available. Please contact our office for details.

Picoprobe®

BY GGB INDUSTRIES INC.

Picoprobe Probe Cards

Feature

- Durable
- DC to 40, 50, 67 or 110 GHz
- Mix RF and DC Contacts
- For MMIC or Module probing
- Individually spring loaded contacts
- Inexpensive, fast, custom fabrication
- 3 capacitor bypass locations available
- Each probe card is custom made to your layout
- Patented coaxial design

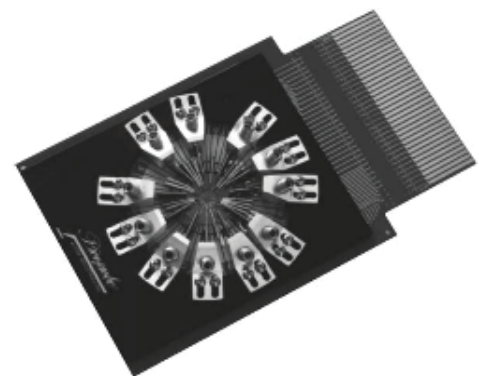

Probe card with eleven RF Picoprobes and fifteen DC needles.

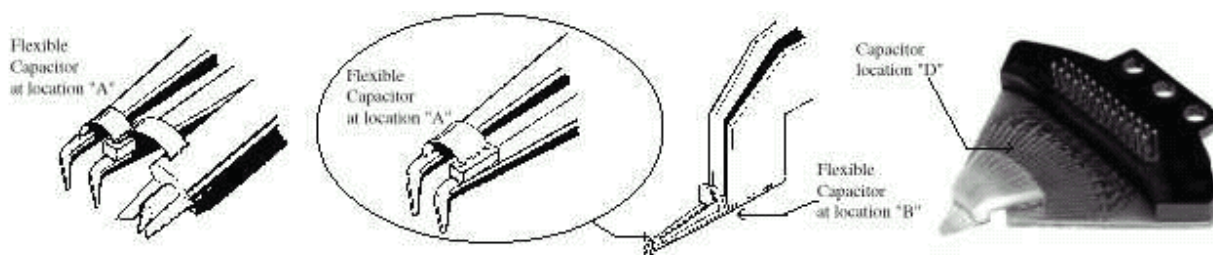

Bypass capacitors for the power supply pins are available in three different locations ("A", "B", and "D") using a process patented by GGB Industries, Inc.

Picoprobe Probe Cards by GGB Industries, Inc., allows for more chip design flexibility because each probe card is custom configured to your circuit for testing wafers on either manual or automatic probe stations. Probe cards with complex layouts consisting of numerous DC contacts and multiple microwave probes with operating frequencies of 40, 50, 67, or 110 GHz can be custom fabricated quickly and inexpensively.



The probe points on a probe card can even be set to different depths so that multi-level modules can be successfully probed. Any pitch (tip spacing) from 50 to 1250 microns may be specified. Larger pitch probes are available by special order. The probes can be configured with Ground-Signal-Ground (G,S,G), Ground-Signal (G,S), or Signal-Ground (S,G) tip footprints.

Each probe card is carefully checked for planarity and with its individually spring loaded Beryllium-Copper tips, provides reliable contacts, even when probing non-planar structures. This reliable low resistance contact is one of the keys to providing highly repeatable measurements. Direct viewing of the probe tips ensures easy and accurate positioning.

Connection to the Model 40A is through a female K connector and is compatible with SMA and 3.5mm connectors. Connection to the Model 50A is through a female 2.4mm connector. Connection to the Model 67A is through a female V connector and is compatible with the 2.4mm connector. Connection to the Model 110A is through a W (1.1mm) or a 1.0 mm connector.

Many different wiring configurations are available for the dc, power supply, or medium frequency needles. Ribbon cable, coaxial cable, and hook up wire are some of the types available. Our standard connectors include banana plugs, BNC connectors, SMA connectors, and (9, 15, 25, or 37) pin D-Subminiature connectors. Other connectors can be specified.

Picoprobe®

BY GGB INDUSTRIES INC.

Model 50

High Performance Microwave Probes



Model 50 Picoprobe® with bias T

The Model 50 Picoprobe® sets new standards in microwave probing performance. Benefiting from coaxial techniques, which have inherent low loss and low dispersion characteristics, the Model 50 Picoprobe®, with or without the bias T option, achieves an insertion loss of less than 0.8 db (typical) and a return loss of greater than 15 db (max.) over its frequency range.

With its individually spring loaded, Beryllium-Copper tips, the Model 50 Picoprobe® provides reliable contacts, even when probing non-planar structures. This reliable low resistance contact is one of the keys to providing highly repeatable measurements (-55 db) at V band frequencies. The Model 50 Picoprobe® also provides direct viewing of the probe tips for accurate positioning.

Any pitch (tip spacing) from 50 microns and up may be specified. The probe can be configured with Ground-Signal-Ground (G,S,G), Ground-Signal (G,S), or Signal-Ground (S,G) tip footprints. We recommend smaller pitches with a G,S,G footprint for best performance.

Features

- **Durable**
- **33 GHz to 50 GHz**
- **Insertion loss 1.0 db max.**
- **Return loss 15 db max.**
- **Individually spring loaded contacts**
- **Measurement repeatability -55 db**
- **Bias T option available**
- **Patented coaxial design**

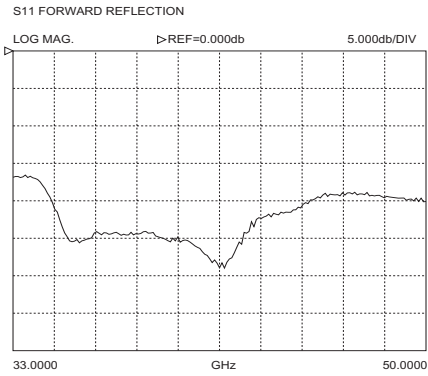

Typical uncalibrated performance of a Model 50-GSG-100-BT while touching a 50 ohm load on our CS-5 calibration substrate.

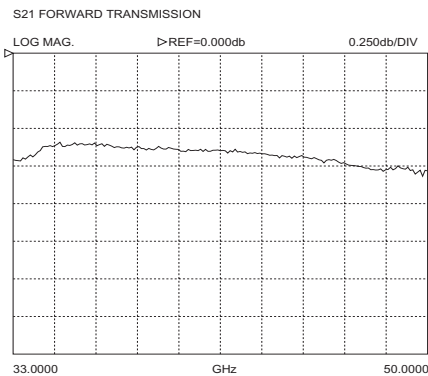

Typical insertion loss of a Model 50-GSG-100-BT

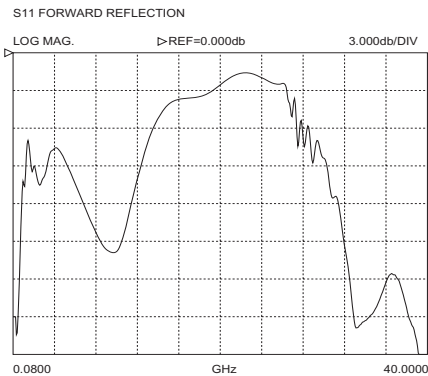

The Model 50 Picoprobe[®] bias T provides a direct low resistance DC path for supplying up to 1.5 A to a device under test. The bias T also has special circuits which add loss at frequencies below the cut off frequency (26.34 GHz) of WR-22 waveguide. This data was taken by launching a, 40 MHz to 50 GHz, signal from the tips of a calibrated Model 67A into the tips of a Model 50-GSG-150-BT. Without this low frequency loss, most active devices will oscillate.

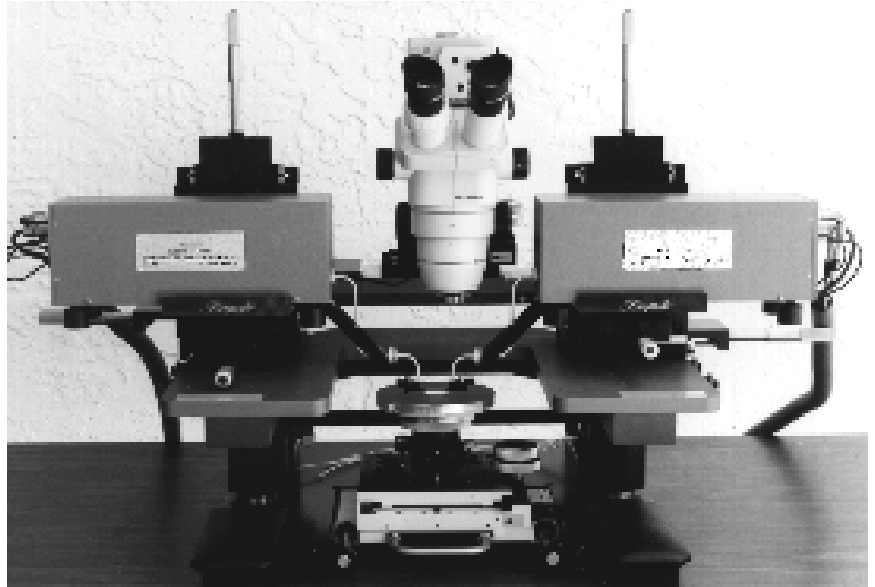

Micropositioners are available to hold Wiltron V band modules so that the module and the probe are micropositioned as a unit. In this way, total ease of positioning can be achieved with minimum insertion loss.

The probes also have a 3 hole mounting adaptor which will fit standard microwave probe stations. In this case, a longer section of waveguide may be desired to add positioning flexibility.

Picoprobe®

BY GGB INDUSTRIES INC.

Model 75

High Performance Microwave Probes



Model 75 Picoprobe® with bias T

The Model 75 Picoprobe® sets new standards in microwave probing performance. Benefiting from coaxial techniques, which have inherent low loss and low dispersion characteristics, the Model 75 Picoprobe®, with or without the bias T option, achieves an insertion loss of less than 1.0 db (typical) and a return loss of greater than 15 db (max.) over its frequency range.

With its individually spring loaded, Beryllium-Copper tips, the Model 75 Picoprobe® provides reliable contacts, even when probing non-planar structures. This reliable low resistance contact is one of the keys to providing highly repeatable measurements (-50 db) at V band frequencies. The Model 75 Picoprobe® also provides direct viewing of the probe tips for accurate positioning.

Any pitch (tip spacing) from 50 microns and up may be specified. The probe can be configured with Ground-Signal-Ground (G,S,G), Ground-Signal (G,S), or Signal-Ground (S,G) tip footprints. We recommend smaller pitches with a G,S,G footprint for best performance. Most customers are using GSG probes with a pitch of 100 to 250 microns.

Features

- **Durable**
- **50 GHz to 75 GHz**
- **Insertion loss 1.25 db max.**
- **Return loss 15 db max.**
- **Individually spring loaded contacts**
- **Measurement repeatability -50 db**
- **Bias T option available**
- **Patented coaxial design**

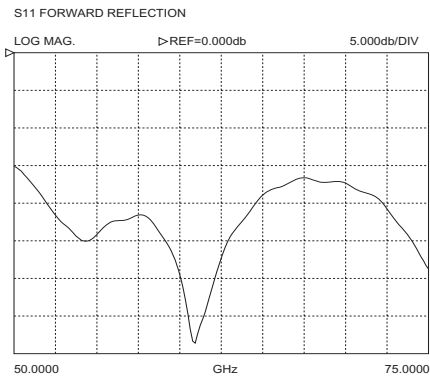

Typical uncalibrated performance of a Model 75-GSG-100-BT while touching a 50 ohm load on our CS-5 calibration substrate.

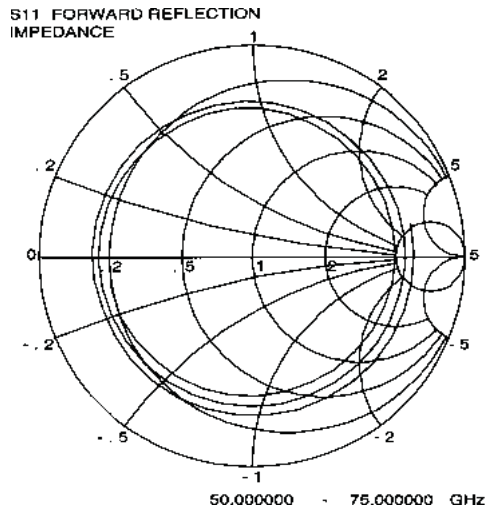

Forward reflection into an open ended 50 ps coplanar line after a one port SOLT calibration was performed using our CS-5 calibration substrate. The smooth inwardly spiraling line shows the increasing loss of the 50 ps coplanar line with frequency, coupled with a smoothly changing phase.

The CS-5 will also perform excellent LRL and LRM V-band calibrations. More data available on request.

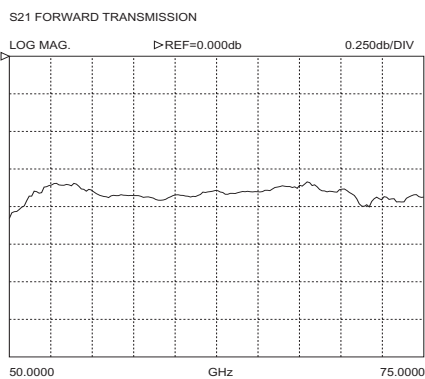

Typical insertion loss of a Model 75-GSG-100-BT

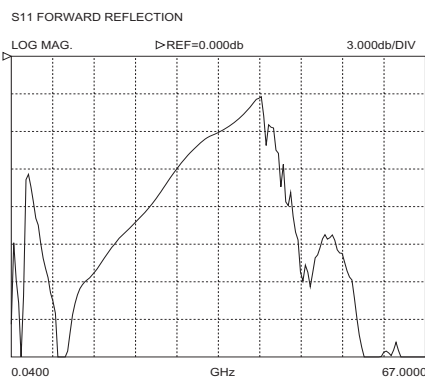

The Model 75 Picoprobe® bias T provides a direct low resistance DC path for supplying up to 1.5 A to a device under test. The bias T also has special circuits which add loss at frequencies below the cut off frequency (39.86 GHz) of WR-15 waveguide. This data was taken by launching a, 40 MHz to 67 GHz, signal from the tips of a calibrated Model 67A Picoprobe® into the tips of a Model 75-GSG-150-BT. Without this low frequency loss most active devices will oscillate.

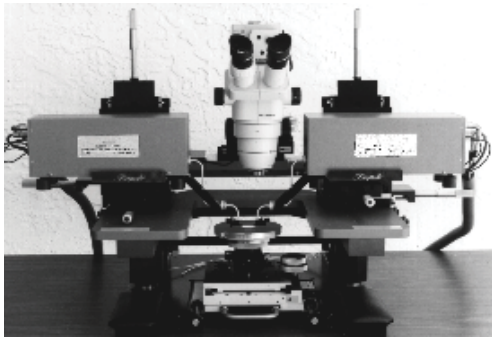

Micropositioners are available to hold Wiltron V band modules so that the module and the probe are micropositioned as a single unit. In this way, total ease of positioning can be achieved with minimum insertion loss.

The probes also have a 3 hole mounting adaptor which will fit standard microwave probe stations. In this case, a longer section of waveguide may be desired to add positioning flexibility.

Covered by US patent # 4,871,964

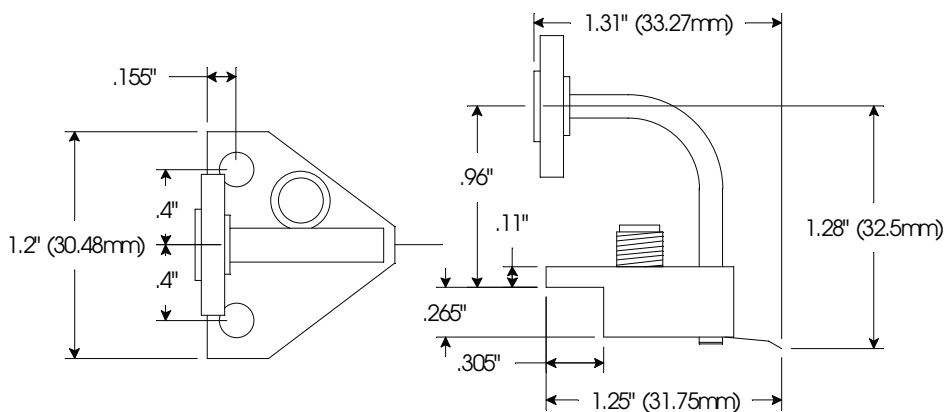

Model 75-BT Waveguide Dimensions

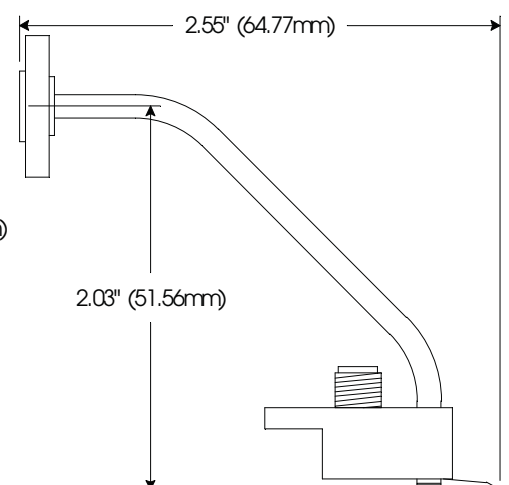

Model 75-BT-M Waveguide Dimensions

Picoprobe®

BY GGB INDUSTRIES INC.

Model 90

High Performance Microwave Probes



Model 90 Picoprobe with bias T

Features

- **Durable**
- **60 GHz to 90 GHz**
- **Insertion loss 1.5 db max. (60 to 90 GHz)**
- **Return loss 15 db max. (60 to 90 GHz)**
- **Individually spring loaded contacts**
- **Measurement repeatability -50 db**
- **Bias T option available**
- **Patented coaxial design**

The Model 90 Picoprobe sets new standards in microwave probing performance. Benefiting from coaxial techniques, which have inherent low loss and low dispersion characteristics, the Model 90 Picoprobe achieves an insertion loss of less than 1.5 db and a return loss of greater than 15 db over its frequency range. The Model 90 has a WR-12 waveguide input and a K connector DC input.

With its individually spring loaded, Beryllium-Copper tips, the Model 90 Picoprobe provides reliable contacts, even when probing non-planar structures. This reliable low resistance contact is one of the keys to providing highly repeatable measurements. The Model 90 Picoprobe also provides direct viewing of the probe tips for accurate positioning.

Any pitch (tip spacing) from 50 to 450 microns may be specified. The probe can be configured with Ground-Signal-Ground (G,S,G), Ground-Signal (G,S), or Signal-Ground (S,G) tip footprints. We recommend smaller pitches with a G,S,G footprint for best performance.

Covered by US patent # 4,871,964

S11 FORWARD REFLECTION

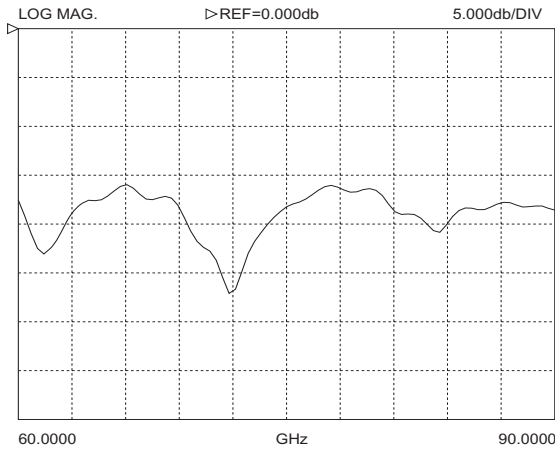

Typical uncalibrated performance of a Model 90-GSG-150-BT while touching a 50 ohm load on our CS-5 calibration substrate.

The CS-5 will also perform excellent LRL and SOLT W-band calibrations. More data available on request.

S21 FORWARD TRANSMISSION

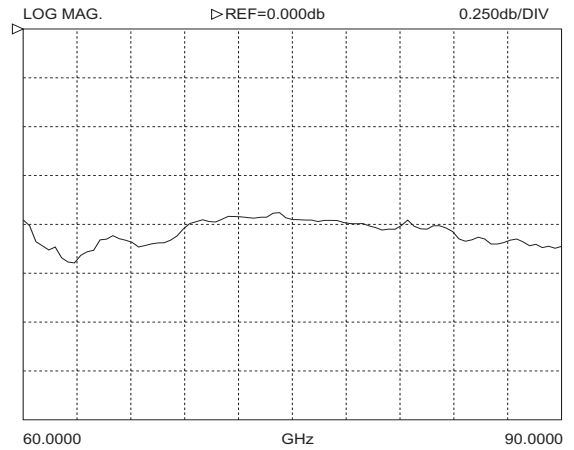

Typical insertion loss of a Model 90-GSG-150-BT

Covered by US patent # 4,871,964

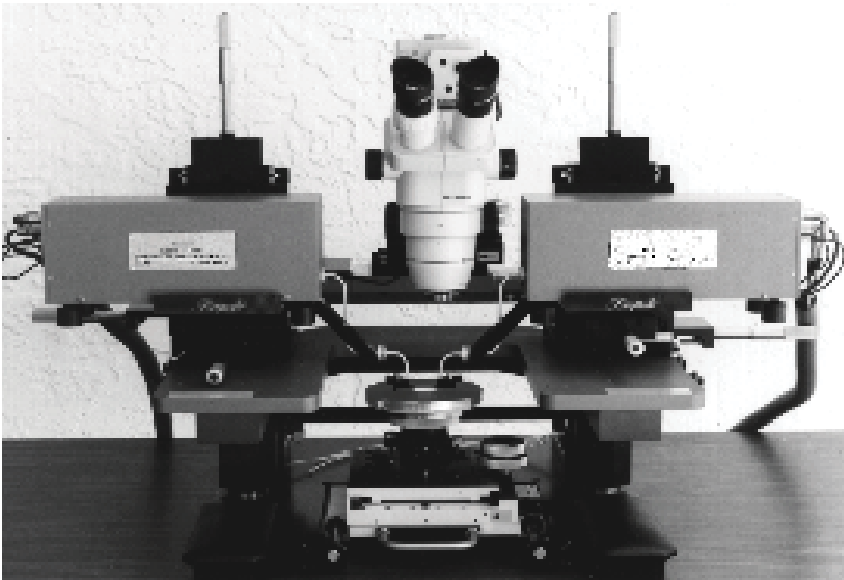

The Model 90 Picoprobe bias T provides a direct low resistance DC path for supplying up to 1.5 A to a device under test. The bias T also has special circuits which add loss at frequencies below the cut off frequency (48.35 GHz) of WR-12 waveguide. Without this low frequency loss most active devices will oscillate.

Micropositioners are available to hold Wiltron W band modules so that the module and the probe are micropositioned as a unit. In this way, total ease of positioning can be achieved with minimum insertion loss.

The probes also have a 3 hole mounting adaptor which will fit standard microwave probe stations. In this case, a longer section of waveguide between the probe and the W band module may be desired to add positioning flexibility.

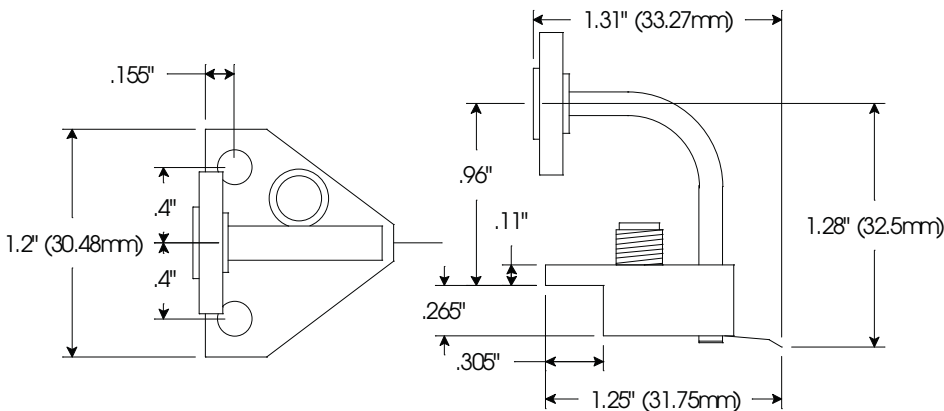

Model 90-BT Waveguide Dimensions

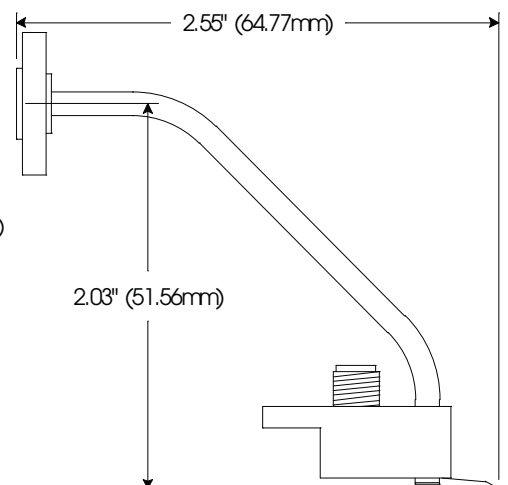

Model 90-BT-M Waveguide Dimensions

Picoprobe®

BY GGB INDUSTRIES INC.

Model 120

High Performance Microwave Probes



Model 120 Picoprobe with bias T

The Model 120 Picoprobe sets new standards in microwave probing performance. Benefiting from coaxial techniques, which have inherent low loss and low dispersion characteristics, the Model 120 Picoprobe achieves an insertion loss of less than 1.75 db and a return loss of greater than 15 db over its frequency range. (see accompanying data)

With its individually spring loaded, Beryllium-Copper tips, the Model 120 Picoprobe provides reliable contacts, even when probing non-planar structures. This reliable low resistance contact is one of the keys to providing highly repeatable measurements (-50 db) at W band frequencies. The Model 120 Picoprobe also provides direct viewing of the probe tips for accurate positioning.

Any pitch (tip spacing) from 50 to 450 microns may be specified. The probe can be configured with Ground-Signal-Ground (G,S,G), Ground-Signal (G,S), or Signal-Ground (S,G) tip footprints. We recommend smaller pitches with a G,S,G footprint for best performance.

Features

- **Durable**
- **75 GHz to 120 GHz**
- **Insertion loss 1.75 db max. (75 to 110 GHz)**
- **Return loss 15 db max. (75 to 110 GHz)**
- **Individually spring loaded contacts**
- **Measurement repeatability -50 db**
- **Bias T option available**
- **Patented coaxial design**

Covered by US patent # 4,871,964

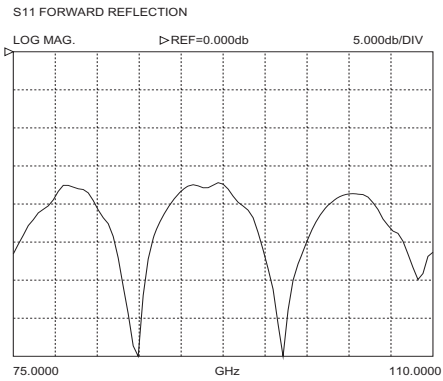

Typical uncalibrated performance of a Model 120-GSG-150-BT while touching a 50 ohm load on our CS-5 calibration substrate.

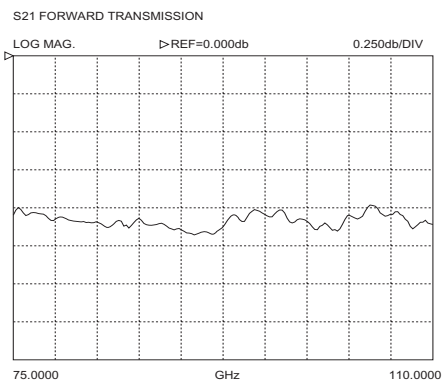

Typical insertion loss of a Model 120-GSG-150-BT

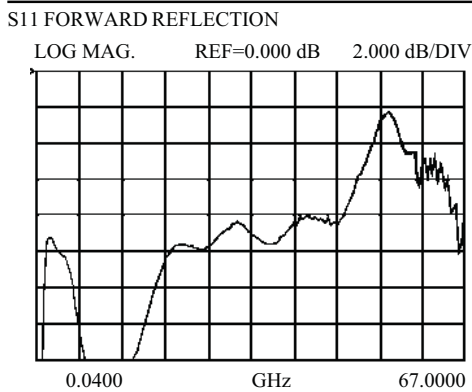

The Model 120 Picoprobe bias T provides a direct low resistance DC path for supplying up to 1.5 A to a device under test. The bias T also has special circuits which add loss at frequencies below the cut off frequency (59.05 GHz) of WR-10 waveguide. This data was taken by launching a 40 MHz to 67 GHz, signal from the tips of a calibrated Model 67A into the tips of a Model 120-GSG-150-BT. Without this low frequency loss most active devices will oscillate.

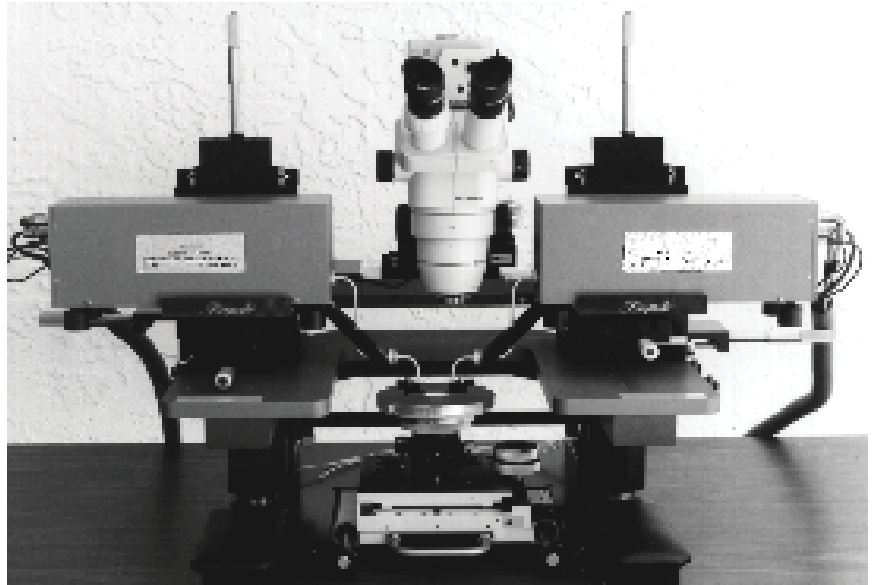

Micropositioners are available to hold Wiltron W band modules so that the module and the probe are micropositioned as a unit. In this way, total ease of positioning can be achieved with minimum insertion loss.

The probes also have a 3 hole mounting adaptor which will fit standard microwave probe stations. In this case, a longer section of waveguide between the probe and the W band module may be desired to add positioning flexibility.

S11 FORWARD REFLECTION IMPEDANCE

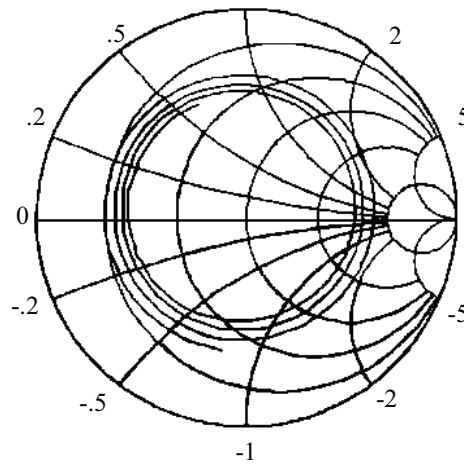

Forward reflection of a Model 120 into an open ended 50 ps coplanar line after an LRM calibration was performed using our CS-5 calibration substrate. The smooth inwardly spiraling line shows the increasing loss of the 50 ps coplanar line with frequency, coupled with a smoothly changing phase.

The CS-5 will also perform excellent LRL and SOLT W-band calibrations. More data available on request.

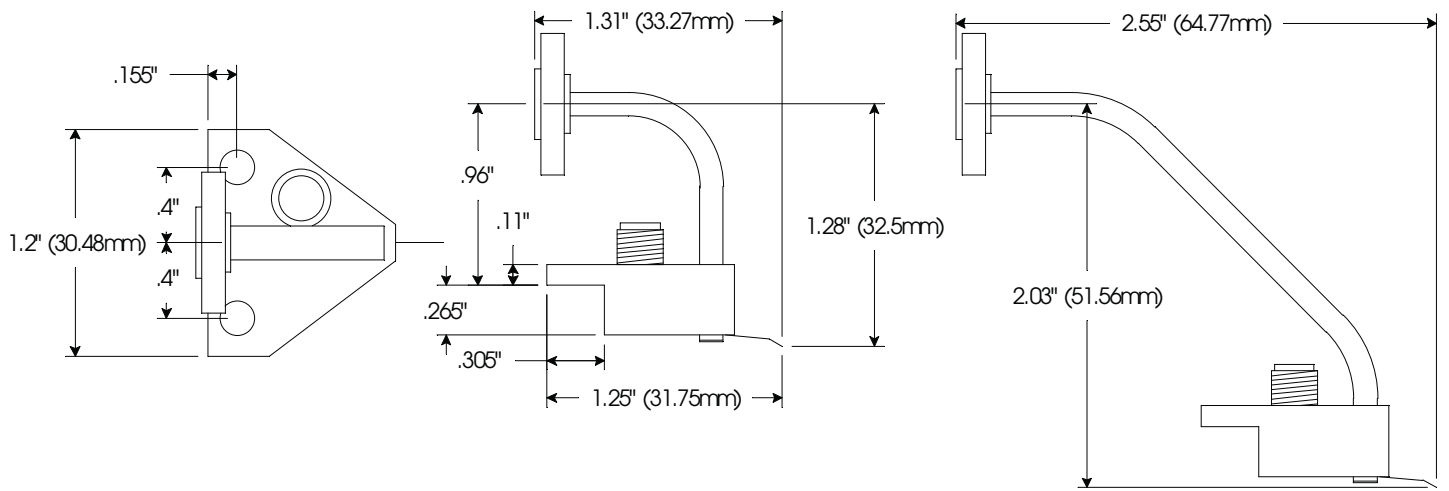

Covered by US patent # 4,871,964

Picoprobe[®]

BY GGB INDUSTRIES INC.

The Picoprobe Model 140, a high performance microwave probe which incorporates a WR-8 waveguide with our patented coaxial design techniques, has inherent low loss and low dispersion characteristics. Like all of our Picoprobe microwave probes, the Model 140 features: individually spring loaded Beryllium-Copper tips which provide reliable contacts even when probing non-planar structures; direct viewing of probe tips for accurate positioning; and can be designed to almost any pitch and footprint. Smaller pitches and Ground-Signal-Ground footprints are recommended for optimum performance. Please contact our office for additional information regarding the performance specifications of the Model 140 Picoprobe.

Picoprobe Model 140 Microwave Probe

Durable

90 to 140 GHz

Patented Coaxial Design

Individually Spring-loaded Contacts

Bias-T Option Available



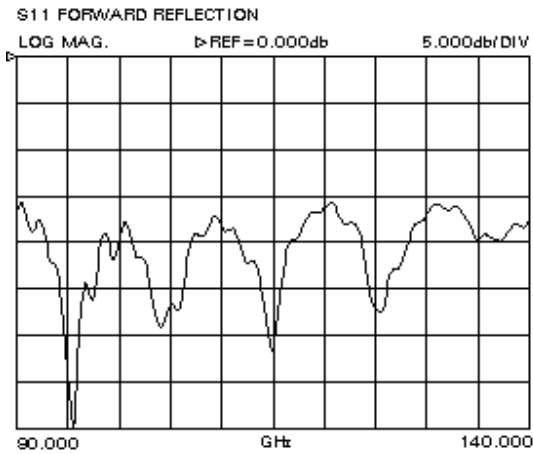

Left: Typical uncalibrated performance of a Model 140-GSG-100-BT

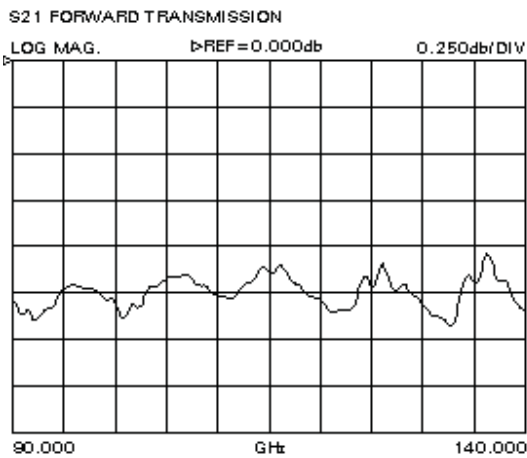

Left: Typical insertion loss of a Model 140-GSG-100-BT.

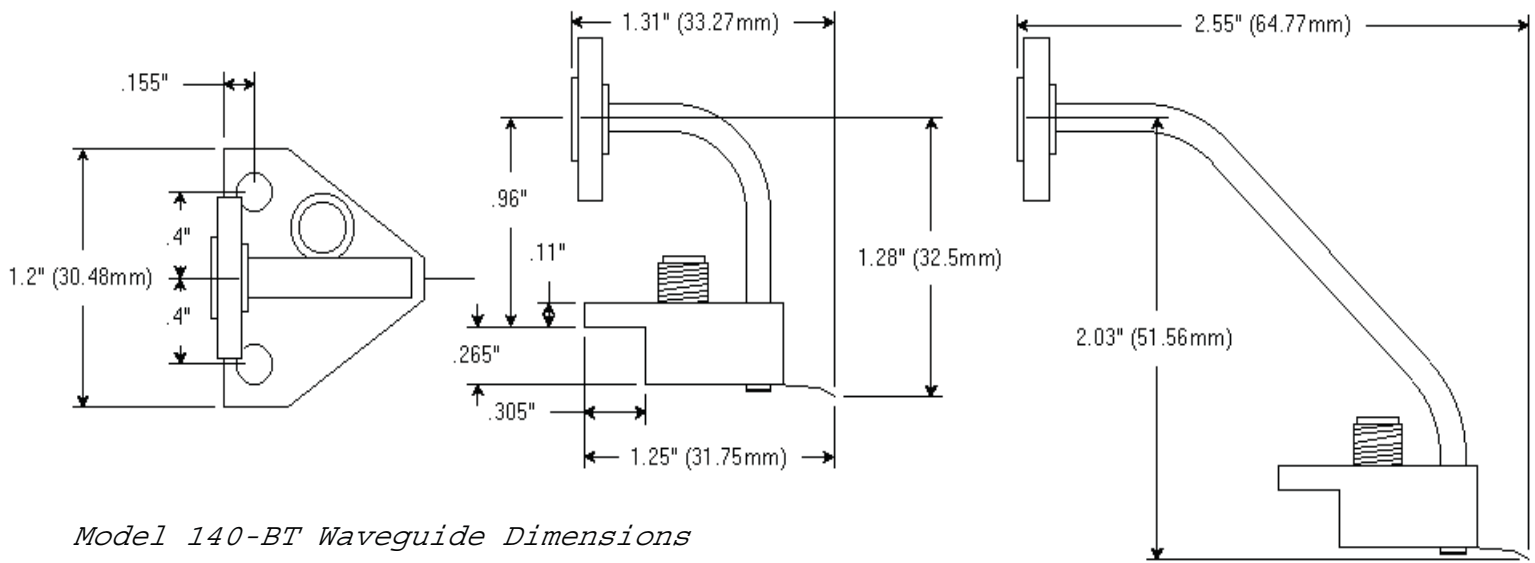

Model 140-BT Waveguide Dimensions

Model 140-BT-M Waveguide Dimensions



High Performance Microwave Probes Model 170

Features

- Durable
- 110 to 170 GHz
- Patented Coaxial Design
- Individually Spring-loaded Contacts
- Bias-T Option Available



FIGURE 1

The PICOPROBE MODEL 170, a high performance microwave probe which incorporates a WR-6 waveguide with our patented coaxial design techniques, has inherent low loss and low dispersion characteristics. Like all of our Picoprobe® microwave probes, the Model 170 features: individually spring loaded Beryllium-Copper tips which provide reliable contacts even when probing non-planar structures; direct viewing of probe tips for accurate positioning; and can be designed to almost any pitch and footprint. Smaller pitches and Ground-Signal-Ground footprints are recommended for optimum performance. Please contact our office for additional information regarding the performance specifications of the Model 170 Picoprobe.

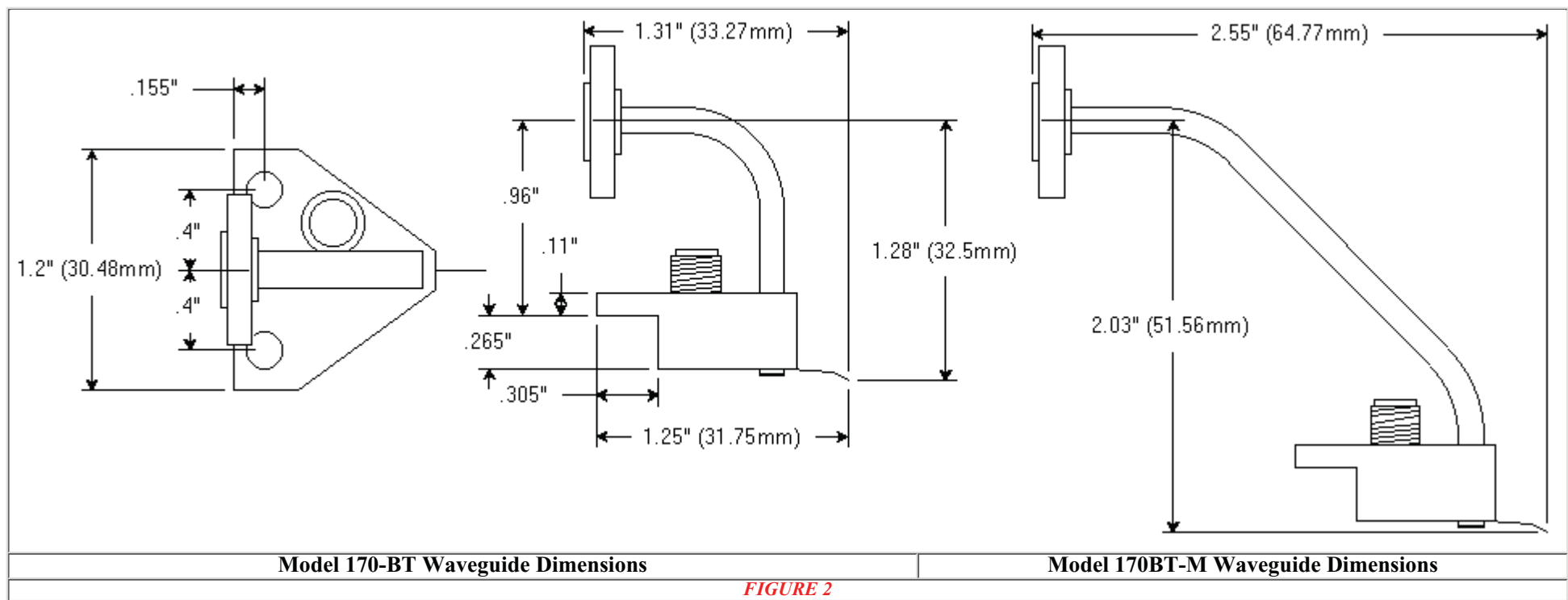

Picoprobe is a registered trademark of GGB Industries, Inc.



High Performance Microwave Probes

Model 220

Features

- Durable
- 140 to 220 GHz
- Insertion loss 2.0 db typ.
- Return loss 15 db typ.
- Individually spring loaded contacts
- Patented Coaxial Design
- Individually Spring-loaded Contacts
- Bias-T Option Available



FIGURE 1

The **PICOPROBE**® **MODEL 220**, a high performance microwave probe which incorporates a WR-5 waveguide with our patented coaxial design techniques, has inherent low loss and low dispersion characteristics. Like all of our Picoprobe microwave probes, the Model 220 features: individually spring loaded Beryllium-Copper tips which provide reliable contacts even when probing non-planar structures; direct viewing of probe tips for accurate positioning; and can be designed to almost any pitch and footprint. Smaller pitches and Ground-Signal-Ground footprints are recommended for optimum performance. Please contact our office for additional information regarding the performance specifications of the Model 220 Picoprobe.

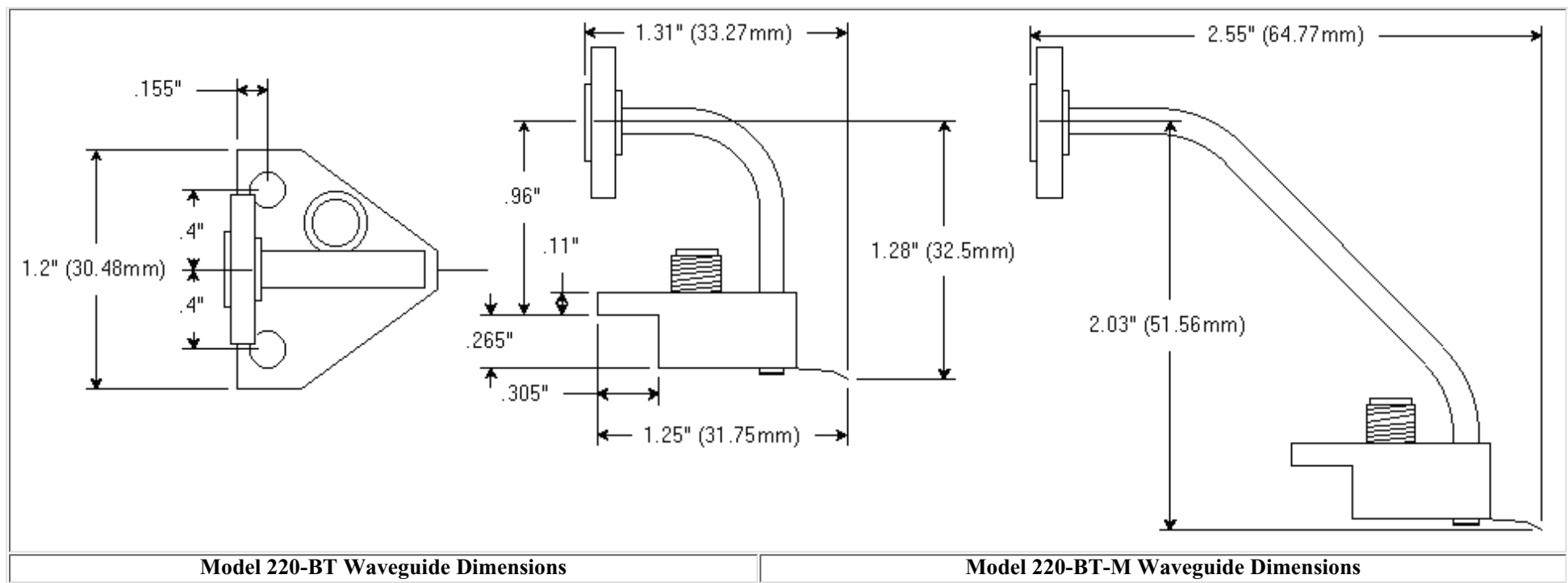

FIGURE 2

Picoprobe is a registered trademark of GGB Industries, Inc.



High Performance Microwave Probes

Model 325

Features

- Durable
- 220 to 325 GHz
- Patented Coaxial Design
- Individually Spring-loaded Contacts
- Bias-T Option Available



The PICOPROBE® MODEL 325, a high performance microwave probe which incorporates a WR-3 waveguide with our patented coaxial design techniques, has inherent low loss and low dispersion characteristics. Like all of our Picoprobe® microwave probes, the Model 325 features: individually spring loaded Beryllium-Copper tips which provide reliable contacts even when probing non-planar structures; direct viewing of probe tips for accurate positioning; and can be designed to almost any pitch and footprint. Smaller pitches and Ground-Signal-Ground footprints are recommended for optimum performance. Please contact our office for additional information regarding the performance specifications of the Model 325 Picoprobe.

Picoprobe®

BY GGB INDUSTRIES INC.

Dual Model 40A Probes



Enlarged photo of Dual Model 40A

Features

- Two probes on one positioner
- Probe to probe spacing user adjustable
- Same performance as regular Model 40A Picoprobe®

The Dual Model 40A consists of two separate probes mounted on a single holder. One probe is fixed to the holder; the other is adjustable. Each probe may be individually configured with GSG, GS, or SG footprints. The probe to probe spacing is user adjustable over a 4,000 micron (160 mil) range. When ordering, an initial setting, of up to 0.75 inches, should be specified. The spacing is measured as the distance between the signal contacts of each probe.

ORDERING INFORMATION

To order a Dual Model 40A, use our regular Model 40A Picoprobe® literature as a guide to specify each probe individually. Then, the orientation of the two probes is specified from left to right looking from the top with the probe tips facing towards you. For example, a

40A-GS-150 /40A-GSG-150-D-300

is a dual probe. The left probe has a GS footprint with 150 microns between the ground and signal. The right probe has a GSG footprint with 150 microns between the grounds and signal. The spacing between the signal of the left probe and the signal of the right probe is 300 microns.

Covered by US patent # 4,871,964

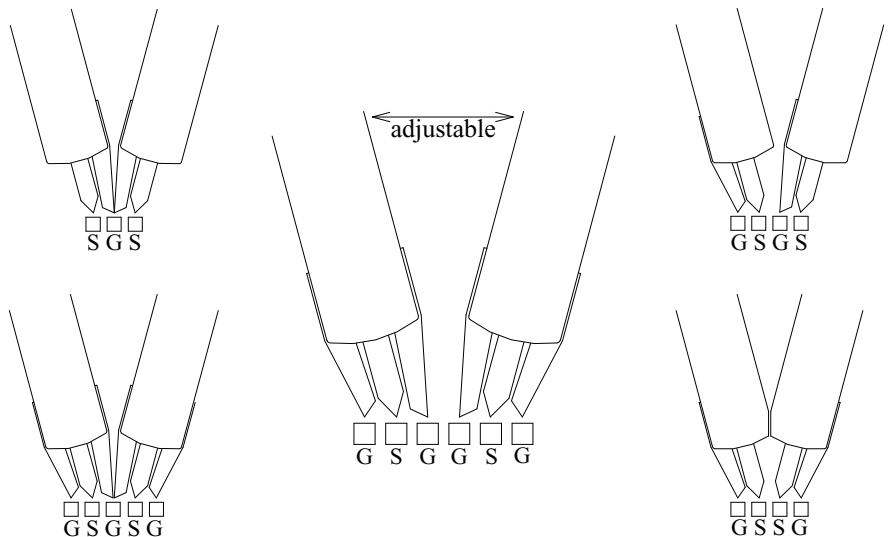

A few examples of probe point configurations

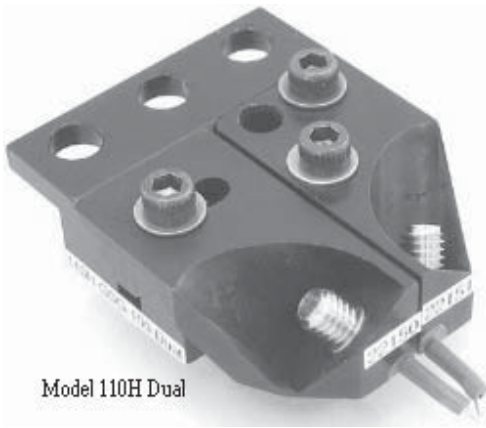

Dual Microwave Probes with frequencies up to 110GHz are available. Choose from either the Model 40A (2.9mm connector), Model 50A (2.4mm connector) Model 67A (1.85mm connector) or the Model 110H (1.0mm connector).

Covered by US patent # 4,871,964

Picoprobe®

BY GGB INDUSTRIES INC.



(Can be mounted on any micropositioner for use with any probing system.)

Picoprobe® Model 7 was designed as a companion probe to Picoprobe® Models 12C and 18C for driving integrated circuit lines so the Models 12C or 18C can be used to measure the response of adjacent nodes. The Model 7 consists of a flexible six foot, 50 ohm coaxial cable accurately terminated to 50 ohms in order to avoid undesirable reflections. A special miniature connector receives replacement coaxial probe tips that provide a shielded environment to within three millimeters of the fine tungsten probe point, thus minimizing capacitive coupling to other parts of the circuit. The replaceable coaxial probe tips are offered in various point sizes and can also be bent to any shape in order to accommodate a variety of probing geometries.

Picoprobe® Model 7A, an unterminated version, can be used for capacitance and resistance measurements or in low to medium speed signal applications where a 50 ohm termination is not required. A flexible coaxial cable of six feet in length is standard on the Model 7A; however, when used for capacitance measurements GGB Industries, Inc., recommends using a shorter three foot cable. If the shorter coaxial cable length is desired for capacitance measurements, please specify it as Model 7A-3ft when ordering.

HIGH TEMPERATURE OPTION

For elevated temperature applications up to 200 degrees C, GGB Industries, Inc. offers Picoprobe® Models 7-HT and 7A-HT. The Models 7-HT and 7A-HT use special temperature resistant probe tips that provide accurate test results under such extreme conditions.

MODEL 7 & MODEL 7A REPLACEMENT TIPS

Part #	Tungsten Probing Wire Shaft Diameter	Point Radius
7-10	10 micron	<0.2 micron
7-22	22 micron	<1.0 micron
7-35	35 micron	<2.0 micron
7-60	60 micron	<3.0 micron
7-125	125 micron	<5.0 micron
7-175	175 micron	<5.0 micron

* Specify high temperature tips by adding an "HT" suffix to the Model 7 & 7A replacement tip part number.

Picoprobe®

BY GGB INDUSTRIES INC.



Picoprobe® Model 12C is a high speed, high input impedance active probe for measuring the internal node voltage of integrated circuits. The input is 1 megohm shunted by 0.1 pf and the rise/fall times are 0.8ns. This instrument has full dc capability and can be used with any oscilloscope. The **Model 12C** was specially designed so that when used in conjunction with a high input impedance oscilloscope signal attenuation is 10:1 and with a 50 Ohm input signal attenuation is 20:1.



Rugged, dependable, and high speed the **Model 12C** presents a very modest load to the integrated circuit. It can be used to troubleshoot high speed bipolar, NMOS and CMOS circuits-even some short holding time dynamic nodes. Each amplifier is individually optimized during manufacture for peak performance and reliability. The **Model 12C** will withstand large input overvoltages. The only known failure mode is the accidental breaking or crushing of the probe tip which can be easily replaced. A large selection of probe tips are available to accommodate a variety of probing needs.

SPECIFICATIONS:

Input Capacitance	0.1pf
Input Resistance	1.0 megohm
Rise/Fall Time	0.8ns
Bandwidth	dc to 500 MHz
Linearity	0.5%
Voltage Range	-10 to +20V*
Gain Accuracy	±3%
Signal Attenuation	(High input impedance oscilloscope) 10 to 1 (50 ohm input) 20 to 1

* Special order Model 12C Picoprobes® are available for -15V.

Picoprobe® Model 12C REPLACEMENT TIPS

Part Number	Tungsten Wire Shaft Diameter	Point Diameter	Probe Tip Housing Shape
12C-1-10	10 micron	< 0.2 micron	
12C-1-22	22 micron	< 1.0 micron	
12C-1-35	35 micron	< 2.0 micron	
12C-1-60	60 micron	< 3.0 micron	
12C-1-125	125 micron	< 5.0 micron	
12C-2-10	10 micron	< 0.2 micron	
12C-2-22	22 micron	< 1.0 micron	
12C-2-35	35 micron	< 2.0 micron	
12C-2-60	60 micron	< 3.0 micron	
12C-2-125	125 micron	< 5.0 micron	
12C-4-10	10 micron	< 0.2 micron	
12C-4-22	22 micron	< 1.0 micron	
12C-4-35	35 micron	< 2.0 micron	
12C-4-60	60 micron	< 3.0 micron	
12C-4-125	125 micron	< 5.0 micron	

Model 12C tips slide easily in and out of the Model 12C probe body. They consist of a housing, a precision resistor/capacitor combination, and a 22 micron tungsten probing wire that is tapered to a fine point of less than one micron. The 22 micron tungsten wire allows ample flexing so the probe point and the circuit tend to remain in contact even in the presence of probe table vibrations. In addition, flexing reduces the damage to the circuit and to the probe point. In most cases if a probe wire becomes bent accidentally, it can be mechanically straightened with no adverse effects on performance. Probe points that have become soiled or dulled can be cleaned and sharpened by shipping the tips back to GGB Industries, Inc.

In addition to the 22 micron tungsten wire with a one micron point, Model 12C tips are available with 10, 35, 60 and 125 micron wires which are sharpened as indicated in the accompanying table.

When ordering a Model 12C Picoprobe,® simply state the make and model number of your probe station and micropositioner. A Picoprobe® with the proper shape will be supplied. For custom stations, please contact our business office for special instructions.

Picoprobe®

BY GGB INDUSTRIES INC.



(Shapes available for use on any micropositioner with any probing system.)

The Picoprobe® Model 34A has been engineered to meet the stringent demands of advanced high frequency circuit designers. This probe combines full DC capability, rise/fall times of 120 ps, and a nominal loading input impedance of 10 MΩ shunted by 0.1 pf. Signal attenuation is 20:1 with a 50 ohm oscilloscope input. Like our other active probes, the Model 34A achieves its bandwidth using just one probe point, which greatly simplifies internal node testing without sacrificing performance. An assortment of user replaceable probe tips are available for a variety of probing needs. The Model 34A is powered by our standard Picoprobe® power supply.

Specifications:

Input Capacitance.....	0.1pf
Input Resistance.....	10.0 MΩ
Rise / Fall Time.....	120 ps (5 V pulse)
Frequency Response.....	DC to 3 GHz (-3 dB)
Operating Range.....	-7V to +10V
Linearity.....	0.5 %
Gain Accuracy.....	±3.0 %
Signal Attenuation.....	20 : 1

Replacement Tips:

Part #	Tungsten Probing Wire Shaft Diameter	Point Radius	Probe Tip Housing Shape
34A-4-10	10 micron	< 0.1 micron	
34A-4-22	22 micron	< 1.0 micron	
34A-4-35	35 micron	< 2.0 micron	
34A-4-60	60 micron	< 3.0 micron	
34A-4-125	125 micron	< 5.0 micron	

Picoprobe®

BY GGB INDUSTRIES INC.

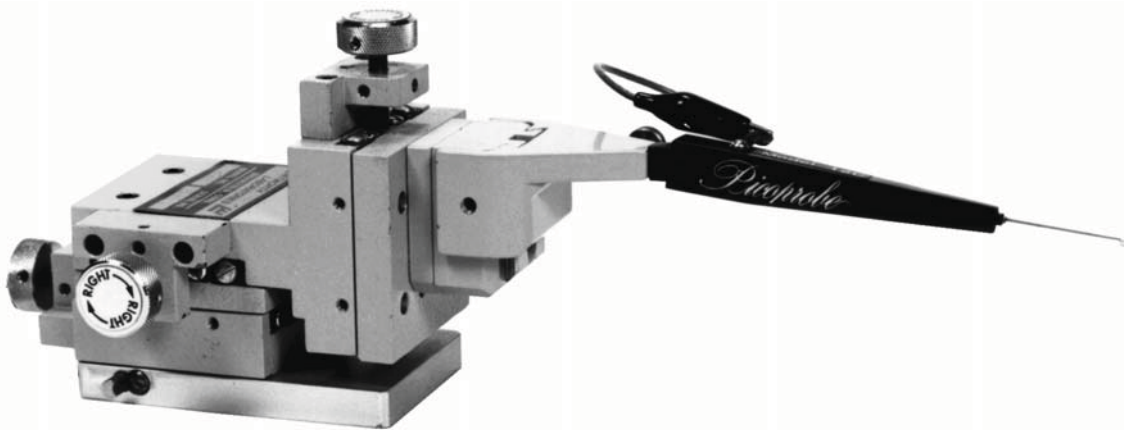

(Shapes available for use on any micropositioner with any probing system)

PICOPROBE® MODEL 18C & PICOPROBE® MODEL 19C combine the most advanced MOS and bipolar technologies with special, low capacitance packaging techniques to achieve truly remarkable electronic measurement capabilities. While being manufactured each instrument is individually optimized for the best possible performance. The extremely low input capacitance and almost negligible input leakage current permits the direct probing of even the most sensitive MOS dynamic nodes. At the same time, the full dc capability of the probe coupled with the high speed capability permits the full characterization of even the fastest circuits.

The 20 micron tungsten probe wire is tapered to an extremely fine point to allow the probing of lines less than 1 micron. The fine probe wire flexes when in contact with the circuit, so that damage to the circuit and probe point is minimized. Also the flexing tends to keep the probe point in contact with the circuit even in the presence of probe table vibrations. MODEL 18C & MODEL 19C probe tips are also available with a 50 micron tungsten probe wire sharpened to approximately 3 microns.



The circuitry located in the MODEL 18C & MODEL 19C Picoprobe® body is very rugged; however, the unprotected MOS input in each probe tip is subject to destruction by electrostatic discharge. Should the probe tip become damaged, it can easily be removed and replaced.

SPECIFICATIONS:

	MODEL 18C	MODEL 19C
Input Capacitance*	0.02pf	0.02pf
Input Leakage	10 ⁻¹⁴ A	10 ⁻¹⁴ A
Rise/Fall Time	1.2 ns	1.2 ns
Frequency Response	dc to 350 Mhz	dc to 350 Mhz
Operating Range	0 to +10V	-7 to +3V
Linearity	0.2% 5V range	0.2% ± 3V range
	2% 10V range	2% -7 to +3 range
Gain Accuracy	±5%	±5%
Signal Attenuation	(High input impedance oscilloscope) 10 to 1	(High input impedance oscilloscope) 10 to 1
	(50 ohm input) 20 to 1	(50 ohm input) 20 to 1

*For 3ns or longer rise and fall signals. Speed limitations of the capacitance cancelling circuitry results in approximately 0.06pf input capacitance for 1 ns or shorter rise or fall inputs.

PICOPROBE® Model 18C & Model 19C REPLACEMENT TIPS

Part Number	Tungsten Wire Shaft Diameter	Point Diameter	Probe Tip Housing Shape
18C-1-10	10 micron	<0.1 micron	
18C-1-20	20 micron	<1.0 micron	
18C-1-50	50 micron	<3.0 micron	
18C-2-10	10 micron	<0.1micron	
18C-2-20	20 micron	<1.0 micron	
18C-2-50	50 micron	<3.0 micron	
18C-4-10	10 micron	<0.1 micron	
18C-4-20	20 micron	<1.0 micron	
18C-4-50	50 micron	<3.0 micron	

When ordering simply state the make and the model of your probe station and micropositioners. A Picoprobe® and tip with the proper shape will be supplied. For home built stations please contact our business office for special instructions.

PICOPROBE® MODEL 19, Model 19C and Model 18B use PICOPROBE® MODEL 18C tips.

Picoprobe®

BY GGB INDUSTRIES INC.



(Can be mounted on any micropositioner for use with any probing system.)

PICOPROBE® MODELS 28 & 29 have been designed to serve the needs of integrated circuit engineers working in the most advanced high speed, submicron, MOS technology. These high frequency instruments include the attractive features of their sister probes, the MODELS 18B & 19, which encompass full dc capability, negligible dc current drain, and extremely low input capacitance. In addition the frequency range of the MODELS 28 & 29 have been extended to a full 1 GHz.

The MODELS 28 & 29 utilize their own special probe tips developed by GGB Industries, Inc. Probe tips can be ordered with 10, 20, or 50 micron diameter tungsten probe wires that are electrochemically sharpened to a point radius of less than 0.2, 1.0 and 3.0 microns respectively. The 10 and 20 micron wires flex when in contact with the circuit so that the potential for damage to the circuit and probe point is minimized. The flexible tip tends to keep the probe point in contact with the circuit even in the presence of probe table vibrations. The heavier 50 micron probe wire can be used when a stronger contact force is required.

The circuitry located in the MODEL 28 & MODEL 29 Picoprobe® body is very rugged; however, the unprotected MOS/SOS (metal on sapphire/silicone on sapphire) input built into each replaceable probe tip is subject to damage by accidental electrostatic discharge. Should the MOS/SOS input or probe point become damaged, the probe tip can easily be removed and replaced at minimal cost.

SPECIFICATIONS:

	MODEL 28	MODEL 29
Input Capacitance.....	0.04pF.....	0.04pF
Input Leakage.....	10^{-14} A.....	10^{-14} A
Rise/Fall Time.....	350ps (+5V pulse or less).....	350ps (\pm 2.5V pulse or less)
Frequency Response.....	dc to 1 GHz (-3dB).....	dc to 1 GHz (-3dB)
Operating Range.....	0 to +9V.....	-7 to +2V
Linearity.....	0.5% (0 to +4V range).....	0.5% (-2 to +2V range)
	2.0% (0 to +9V range).....	2.0% (-7 to 2 range)
Gain Accuracy.....	\pm 3%.....	\pm 3%
Signal Attenuation.....	20 to 1 (50 ohm oscilloscope input).....	20 to 1 (50 ohm oscilloscope input)

PICOPROBE® Model 28 & Model 29 REPLACEMENT TIPS

Part Number	Tungsten Wire Shaft Diameter	Point Radius	Probe Tip Housing Shape
28-5-10	10 micron	<0.1 micron	 (Can be bent to any shape desired)
28-5-20	20 micron	<1.0 micron	
28-5-50	50 micron	<3.0 micron	

In most cases if a probe tip becomes bent accidentally, it can be mechanically straightened with no adverse effects on performance. Probe points that have become soiled or dulled can be cleaned and resharpened by shipping the tips back to GGB Industries, Inc.

When ordering a Model 28 or Model 29 Picoprobe,® simply state the make and the model of your probe station and micropositioner. A Picoprobe® and tip with the proper shape will be supplied. For custom built stations, please contact our business office for special instructions.



Tungsten Probe Tips
T-4
Series

T-4 tips are for use in most standard commercial micropositioners for probing integrated circuits, pads, or lines. GGB Industries, Inc., does not manufacture a probe amplifier for use with this tip.

Each T-4 tip uses the same 10, 22, 35, 60, or 125 micron diameter tungsten wire as our Model 12C Picoprobe®, but is mounted to a 0.020 inch diameter, 2 inch long copper shaft.

An advantage of the 10 and 22 micron models pointed out by some of our users is that because the tungsten probing wire is thin and flexible it minimizes damage to the integrated circuit and allows them to probe the device for a much longer period of time. The flexible T-4 tip remains in contact with the circuit even in the presence of probe table vibrations.

T-4 tips are not recommended for use on sensitive nodes where capacitance loading could be a problem. If you would like samples, please contact our office.



Scanning electron microscope photograph of a T-4-10 Tungsten point. (1 micron = 0.5 cm)

Part Number	Tungsten Wire Diameter	Point Radius
T-4-10	10 micron	<0.1 micron
T-4-22	22 micron	<1.0 micron
T-4-35	35 micron	<2.0 micron
T-4-60	60 micron	<3.0 micron
T-4-125	125 micron	<5.0 micron

Picoprobe®

BY GGB INDUSTRIES INC.

Solid Tungsten Probe Tips ST Series

The ST Series of probe tips, available from GGB Industries, Inc., are precision crafted from a 0.020 inch (0.51 mm) diameter solid tungsten shaft that is electrochemically sharpened to a specified point. These durable 1.50 inch long solid shaft tips are for use in most standard micropositioners when probing an integrated circuit, pad, or line. Several different tip sizes ranging from 0.5 to 10 microns are available to accommodate any probing need.

The ST Series tips offer reliable long-term probing at both an affordable price and the convenience of immediate delivery from our well-stocked facility. A nickel-plated option is available allowing the user to solder directly to the shaft of the tip. When ordering the nickel-plated option, please add the suffix "NP" to the end of the part number. Custom sizes are available. If you would like samples, please contact our office.

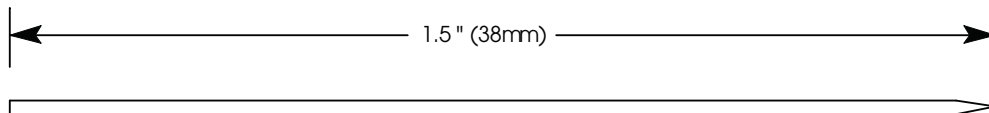

The ST Series Probe Tip is a 0.020" (0.51 mm) solid tungsten shaft sharpened to a precise point.

ST Series Probe Tip Part Number Designation / Ordering Information

Part Number	Solid Tungsten Shaft Diameter	Point Radius (in microns)
ST-20-0.5	0.020" (0.51mm)	< 0.5 micron
ST-20-1	0.020" (0.51mm)	< 1.0 microns
ST-20-2	0.020" (0.51mm)	< 2.0 microns
ST-20-5	0.020" (0.51mm)	< 5.0 microns
ST-20-10	0.020" (0.51mm)	< 10.0 microns

** Note--Only solid tungsten and 0.020 inch shafts are available in the ST Series.
A nickel-plated option can be ordered by adding the suffix "NP" to the end of the part number.*